

Service
Service
Service

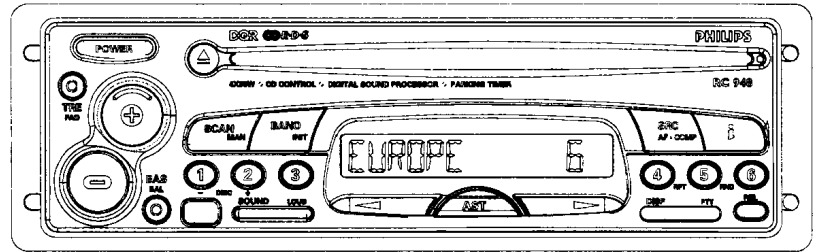

COMPACT
disc
DIGITAL AUDIO

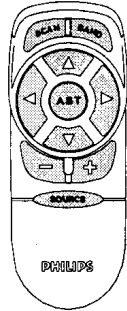
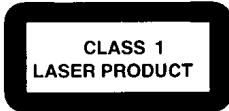

For repair information of the CD player, see Service Manual No 4822 725 24095 of CD mechanism CDM9

Service Manual

Contents	page
Technical data	2
Controls - Connexions	3 - 3a
Init mode	4 - 4a
Checks and alignment	5 - 5a
Power supply organization	6 - 6a
CDSP description	7 - 7a
CDSP pinning	8 - 8a
Block diagram	9 - 9a
Front schematic diagram part 1	10 - 10a
Front schematic diagram part 2	11 - 11a
Front PWB layout	12 - 12a
Front partslist	13 - 13a
Tuner parts schematic diagram	14 - 14a
Power supply part 00 schematic diagram	15 - 15a
Power supply part 01 schematic diagram	16 - 16a
Power supply part 02 schematic diagram	17 - 17a
Power supply part 03 schematic diagram	18 - 18a
Main PWB layout - top side view	19 - 19a
Sound process part 00 schematic diagram	20 - 20a
Sound process part 01 schematic diagram	21 - 21a
Microcontroller part 00 schematic diagram	22 - 22a
Microcontroller part 01 schematic diagram	23 - 23a
Main PWB layout - bottom side view	24 - 24a
Tape part schematic diagram	25 - 25a
Power amplifier part schematic diagram	26 - 26a
Opening the front	27
Mechanical partslist - Technician's remarks	28
Exploded view	29 - 29a
Electrical partslist	30 - 30a - 31 - 32

12 V



PHILIPS

BLOCK DIAGRAM

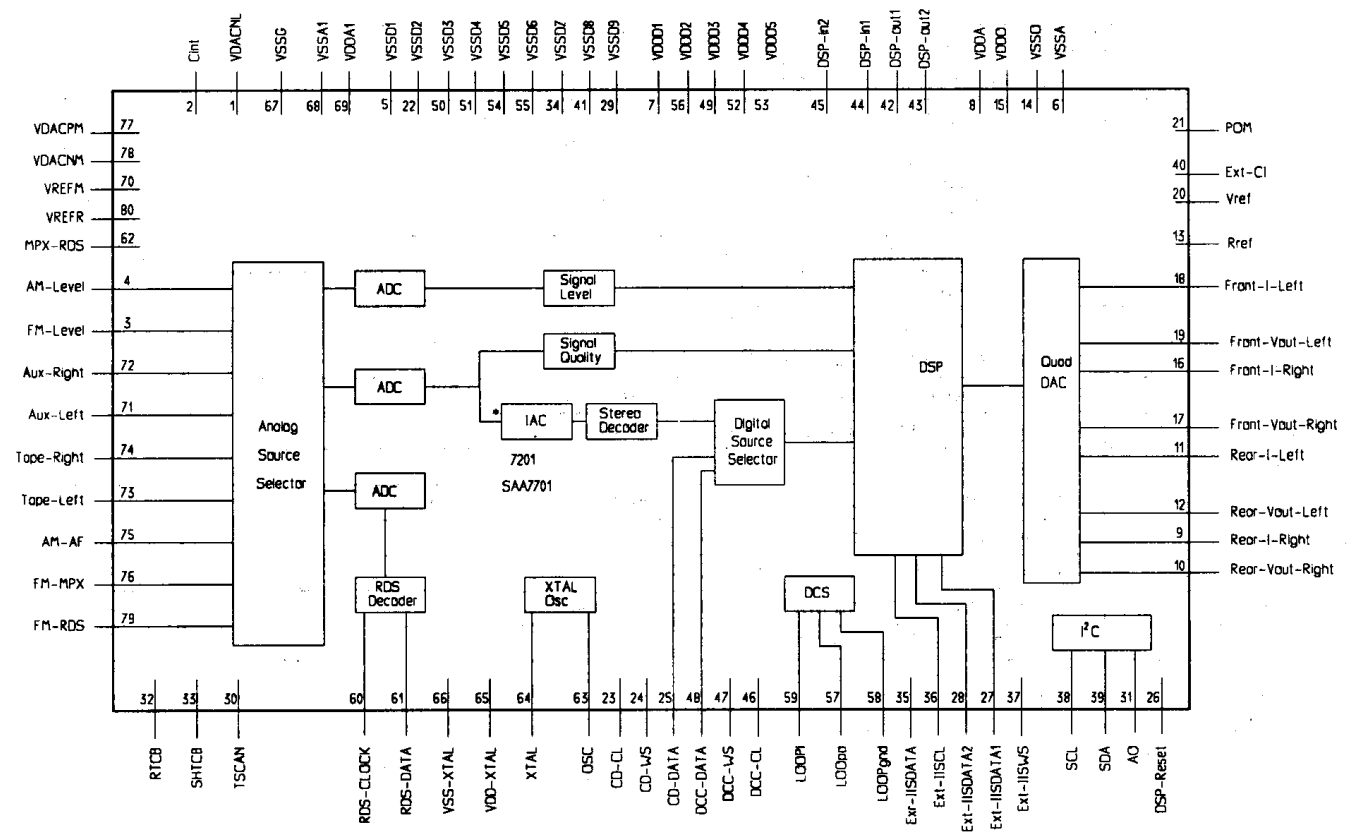

FUNCTIONAL DESCRIPTION

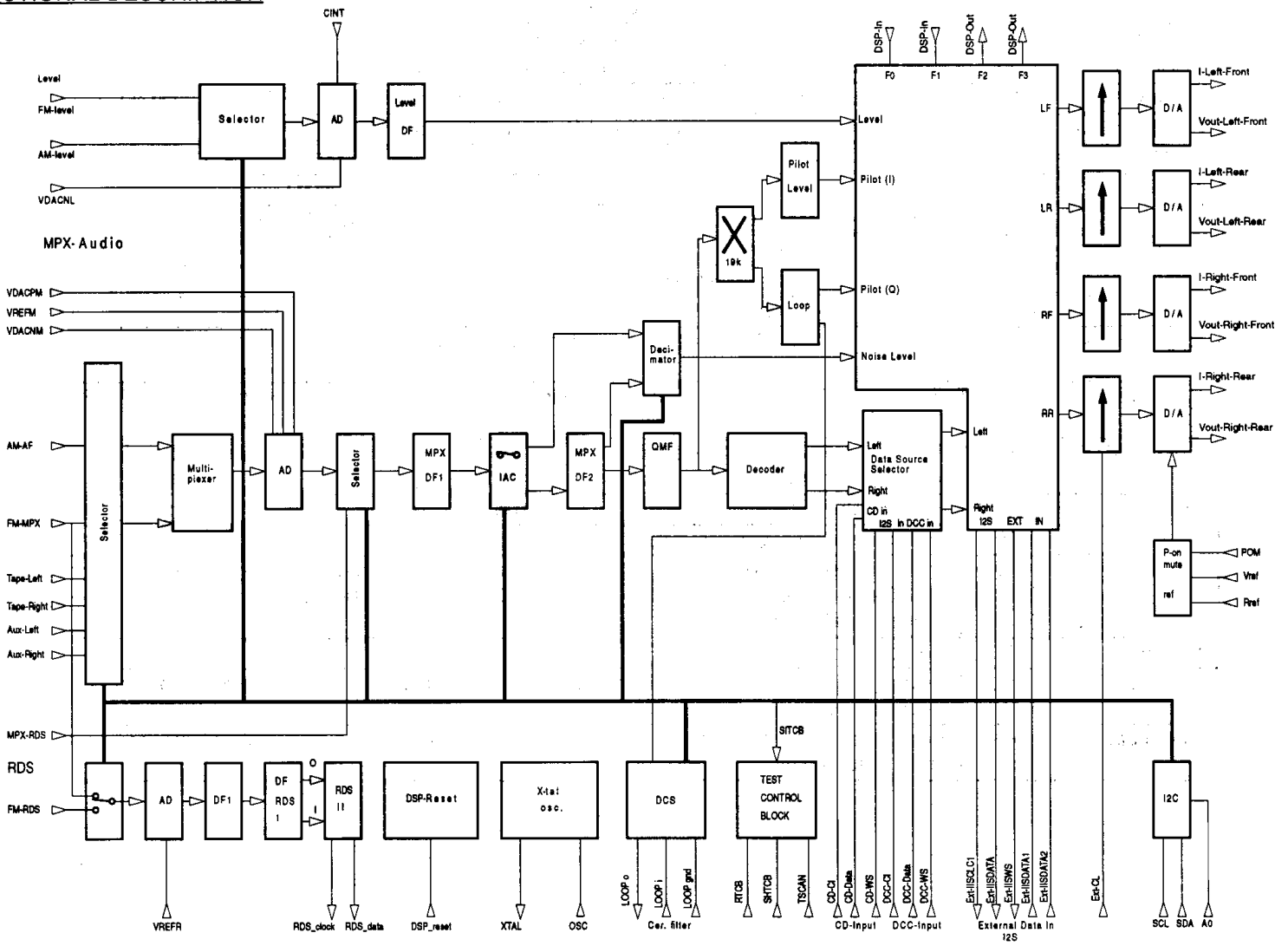

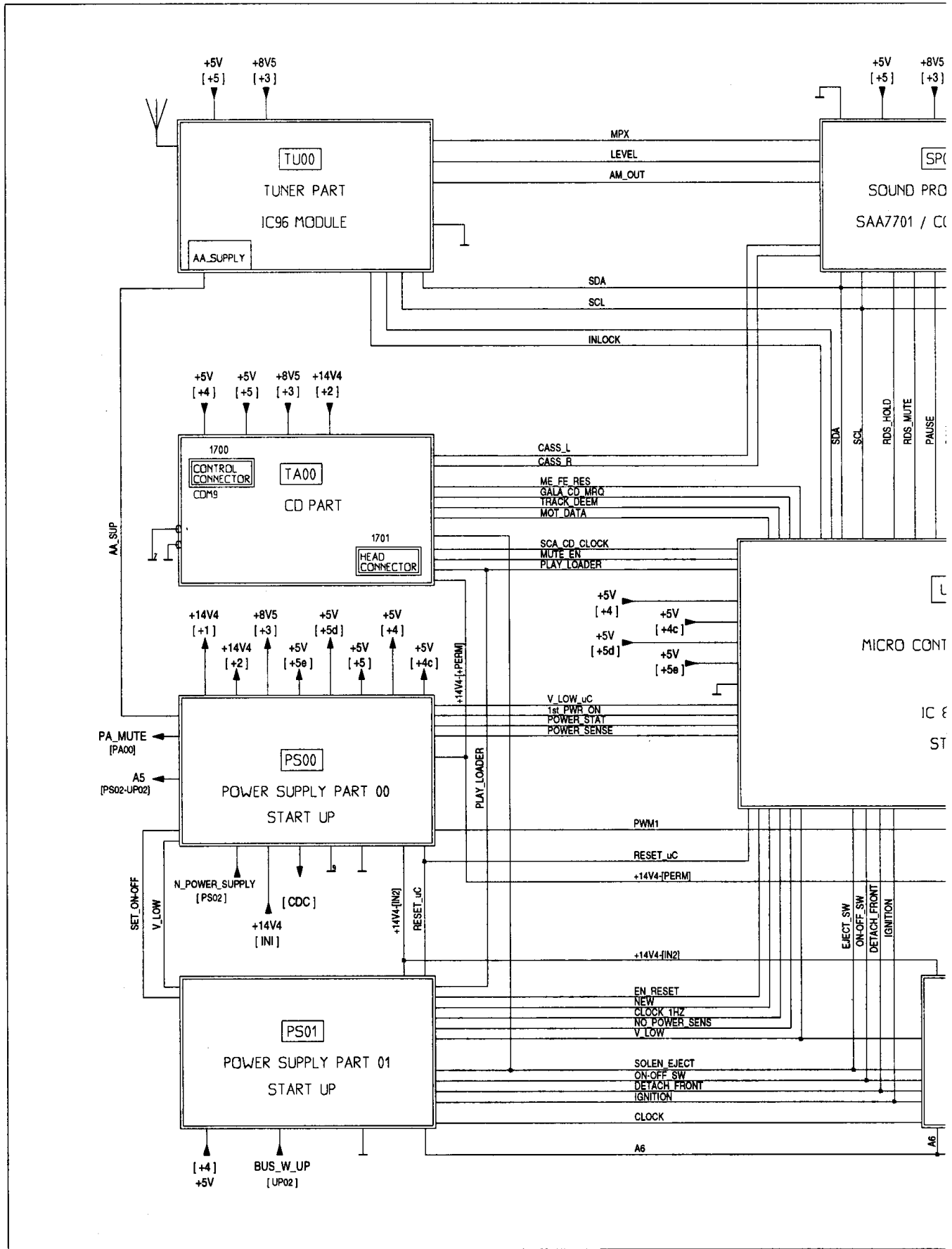

ELECTRICAL BLOC DIAGRAM

22DC948/00

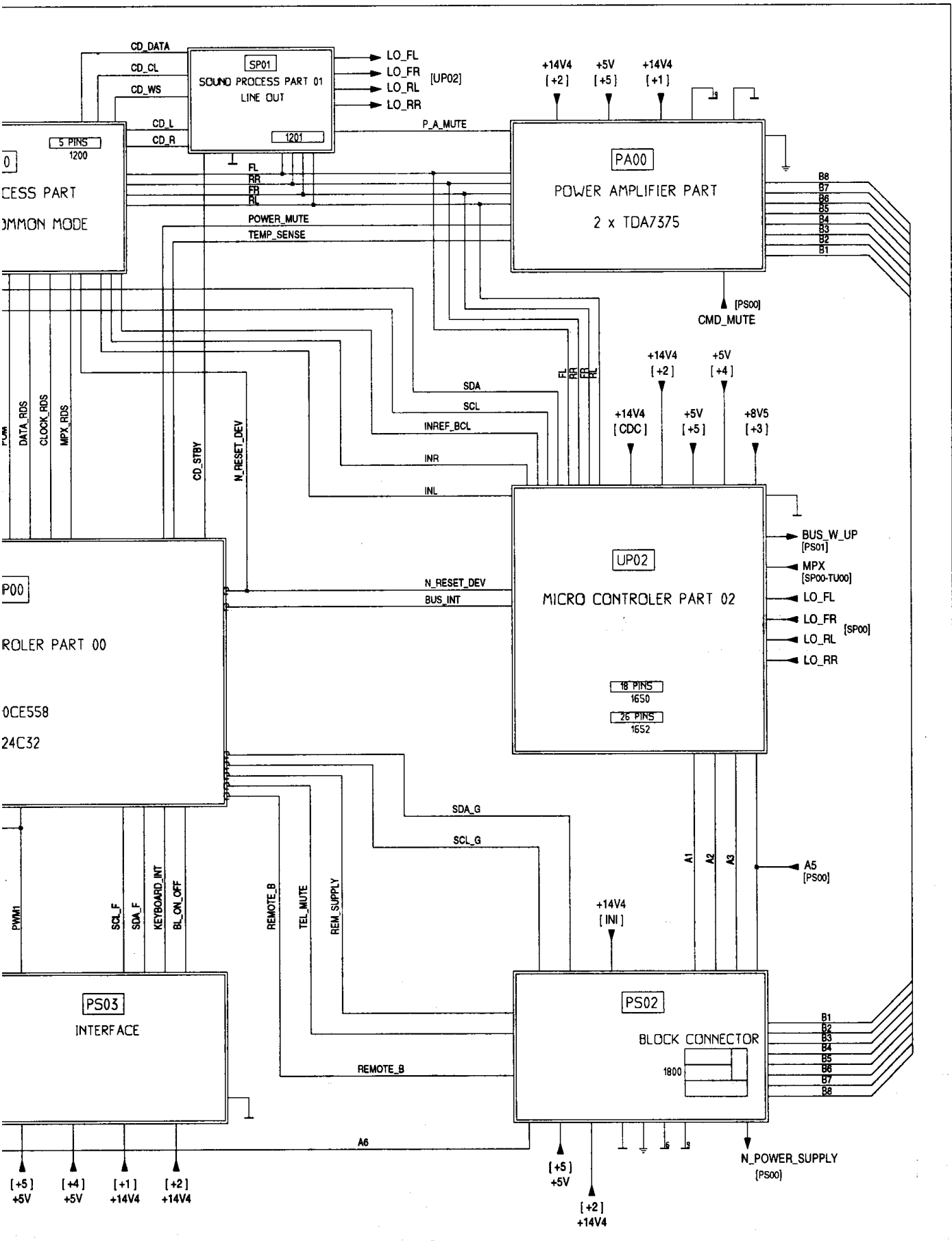

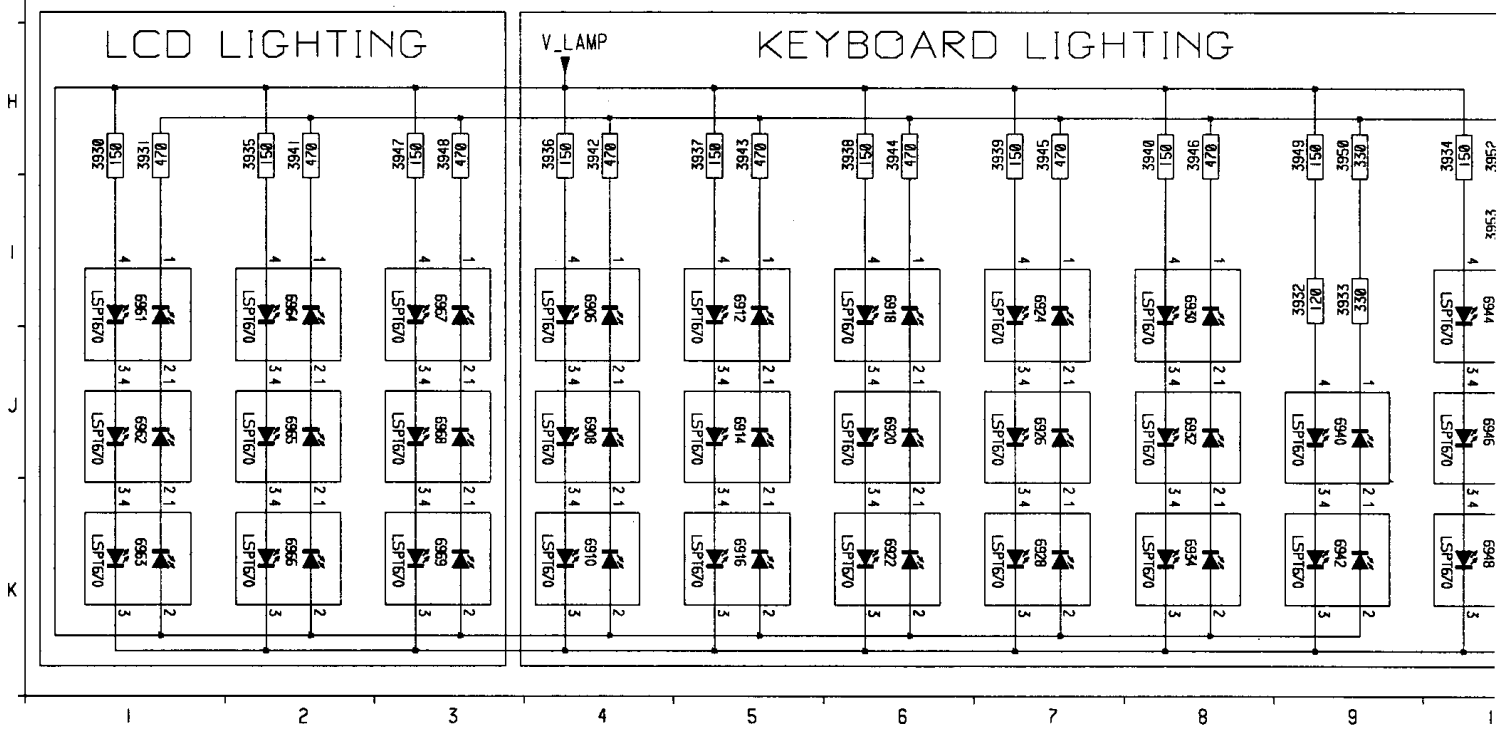
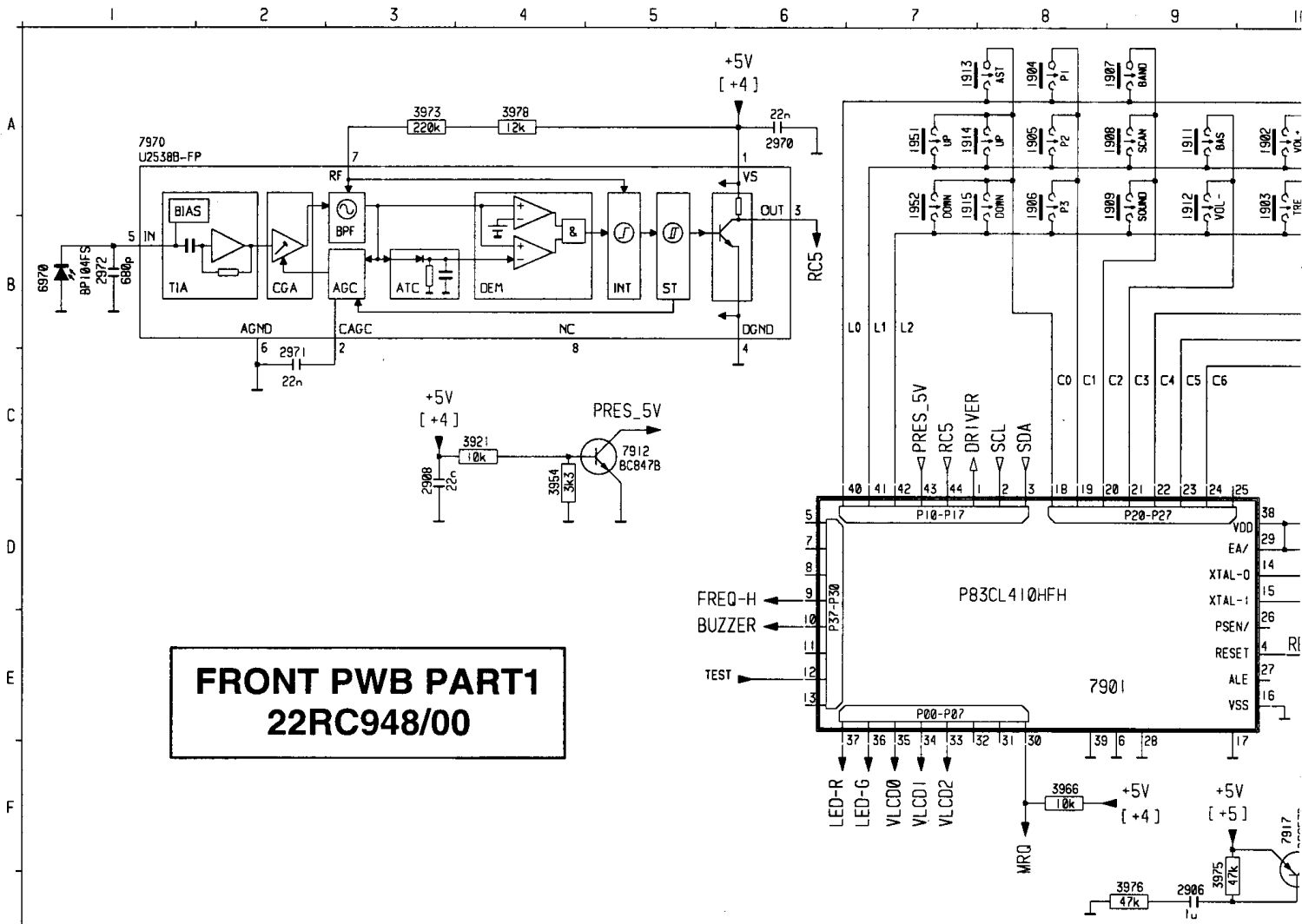

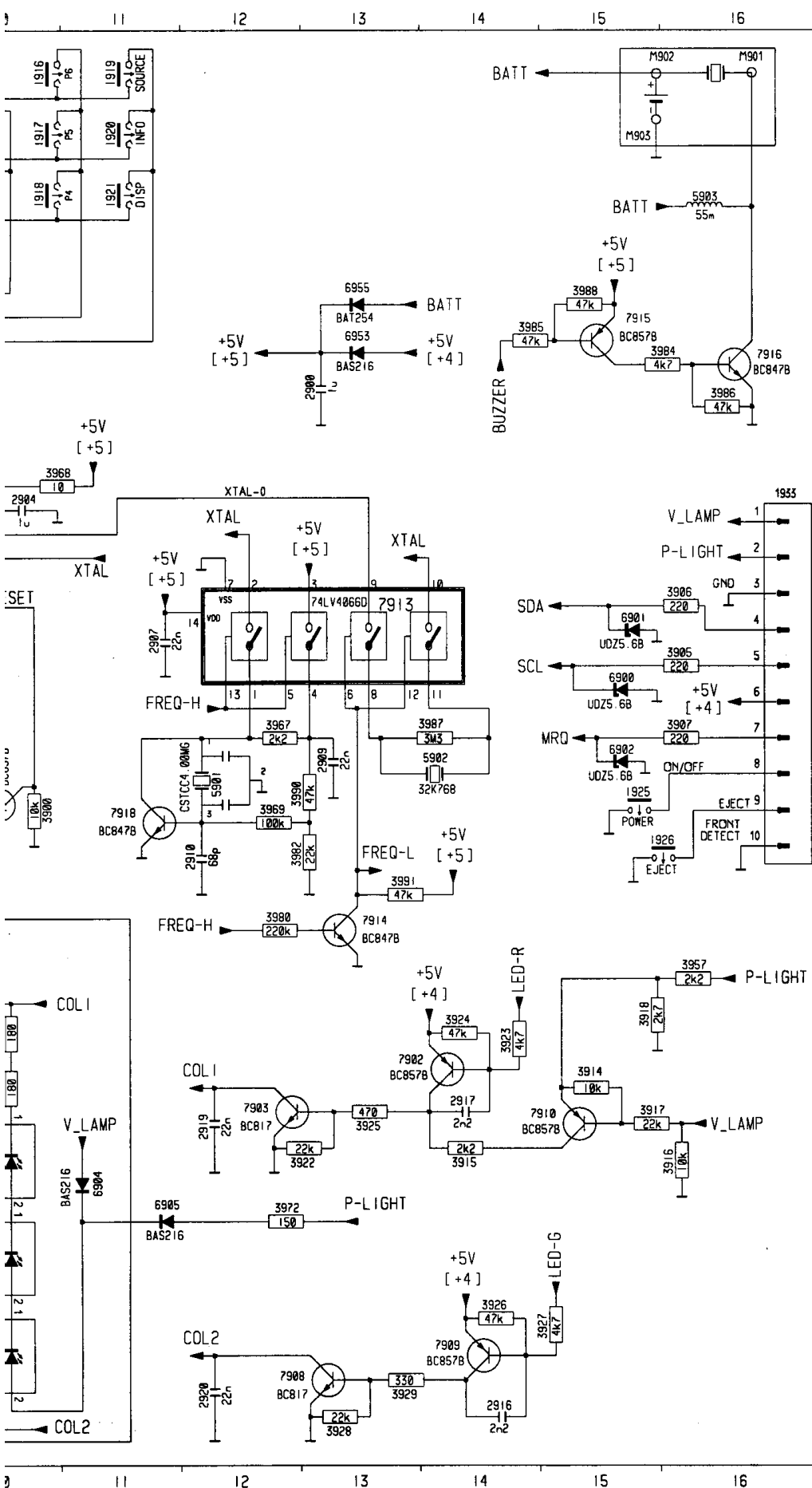

1902	A10	3949	H 9
1903	A10	3950	H 9
1904	A 8	3952	H10
1905	A 8	3953	I10
1906	A 8	3954	D 4
1907	A 9	3957	H16
1908	A 9	3966	F 8
1909	A 9	3967	F12
1911	A 9	3968	D10
1912	A 9	3969	G12
1913	A 7	3972	J12
1914	A 7	3973	A 3
1915	A 7	3975	G 9
1916	A10	3976	G 9
1917	A10	3978	A 4
1918	A10	3980	G12
1919	A11	3982	G12
1920	A11	3984	C16
1921	A11	3985	C14
1925	F15	3986	C16
1926	G16	3987	F14
1933	D16	3988	B15
1951	A 7	3990	F12
1952	A 7	3991	G13
2900	C13	5901	F12
2904	D10	5902	F14
2906	G 9	5903	A16
2907	E11	6900	E15
2908	D 3	6901	E15
2909	F13	6902	F15
2910	G12	6904	J11
2916	K14	6905	J11
2917	I14	6906	I 4
2919	I12	6908	J 4
2920	K12	6910	K 4
2970	A 6	6912	J 5
2971	C 2	6914	J 5
2972	B 1	6916	K 5
3900	G10	6918	I 6
3905	E16	6920	J 6
3906	E16	6922	K 6
3907	F16	6924	I 7
3914	I15	6926	J 7
3915	I14	6928	K 7
3916	I16	6930	I 8
3917	I15	6932	J 8
3918	H15	6934	K 8
3921	C 4	6940	J 9
3922	I13	6942	K 9
3923	H14	6944	I10
3924	H14	6946	J10
3925	I13	6948	K10
3926	K14	6953	C13
3927	K15	6955	B13
3928	K13	6961	I 1
3929	K13	6962	J 1
3930	H 1	6963	K 1
3931	H 1	6964	I 2
3932	I 9	6965	J 2
3933	I 9	6966	K 2
3934	H10	6967	I 3
3935	H 2	6968	J 3
3936	H 4	6969	K 3
3937	H 5	6970	B 1
3938	H 6	7901	E 8
3939	H 7	7902	I14
3940	H 8	7903	I12
3941	H 2	7908	K13
3942	H 4	7909	K14
3943	H 5	7910	I15
3944	H 6	7912	C 5
3945	H 7	7913	E13
3946	H 8	7914	G13
3947	H 3	7915	B15
3948	H 3	7916	C16
		7917	F10
		7918	G11
		7970	A 1

**FRONT PWB PART2
22RC948/00**

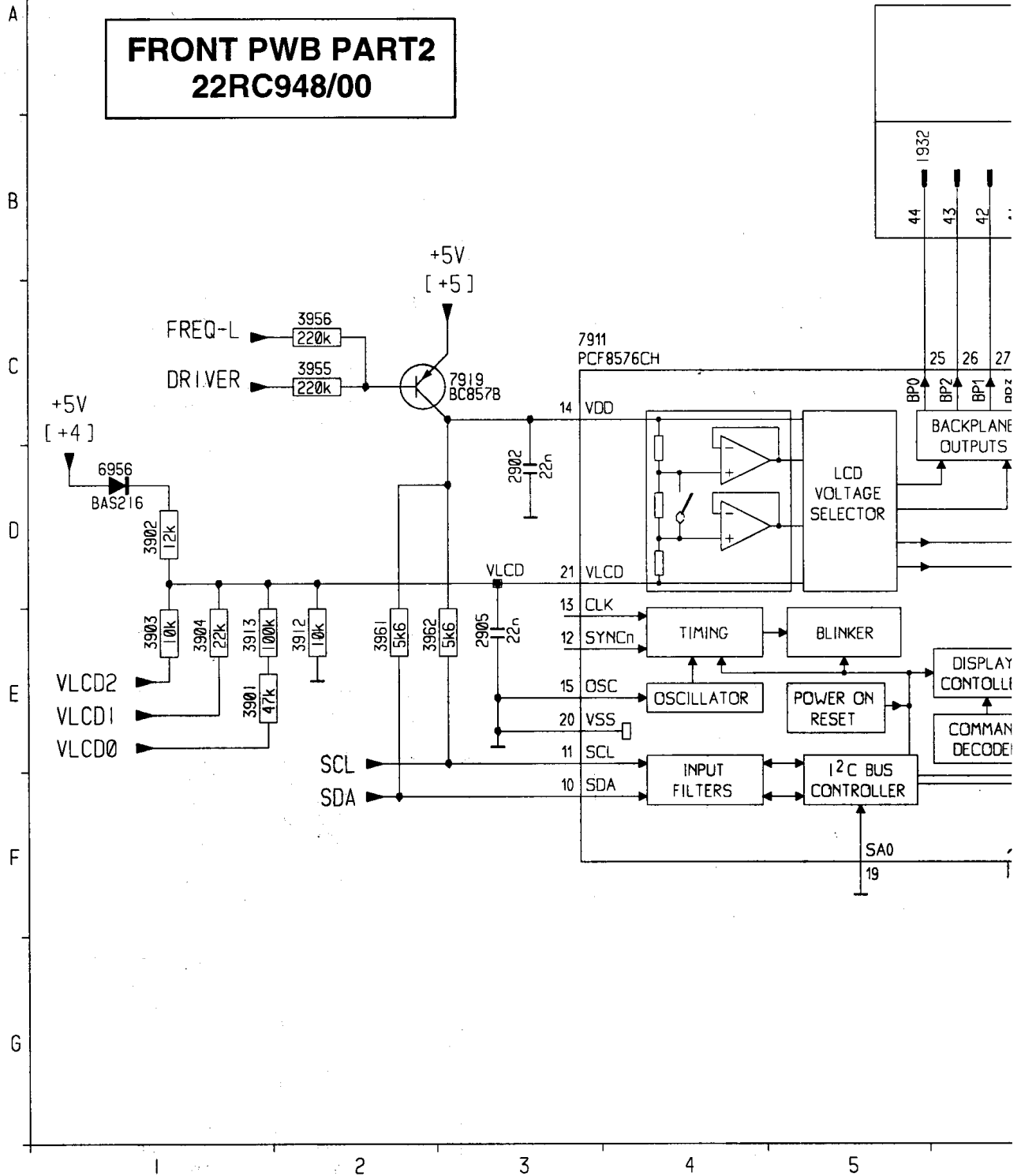

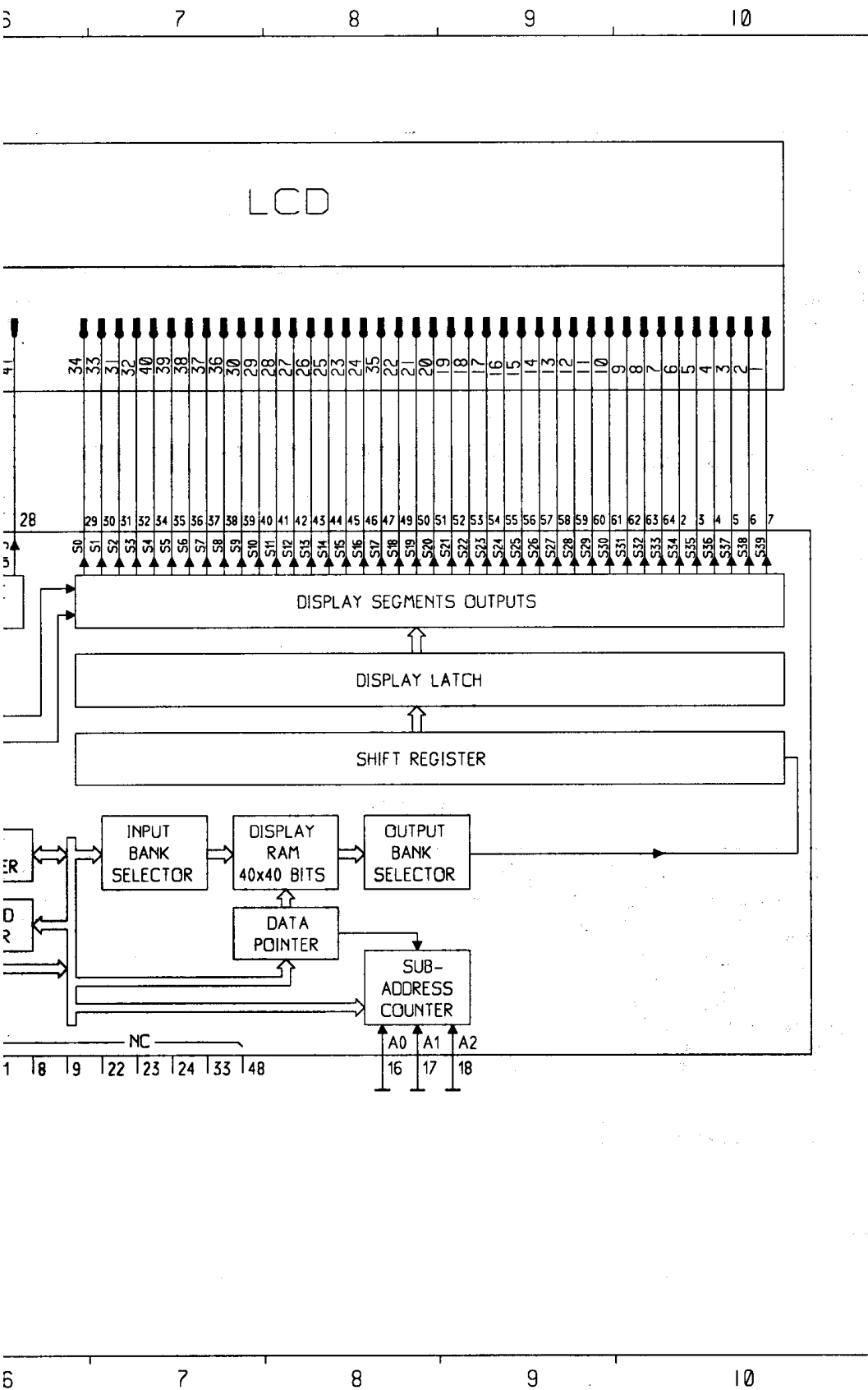

- 1932 B 5
- 2902 D 3
- 2905 E 3
- 3901 E 1
- A 3902 D 1
- 3903 E 1
- 3904 E 1
- 3912 E 2
- 3913 E 1
- 3955 C 2
- 3956 C 2
- B 3961 E 2
- 3962 E 2
- 6956 D 1
- 7911 C 3
- 7919 C 3

C

D

E

F

G

IC96 MODULE

Not reparable module. Do not open and do not try to repair yourself!

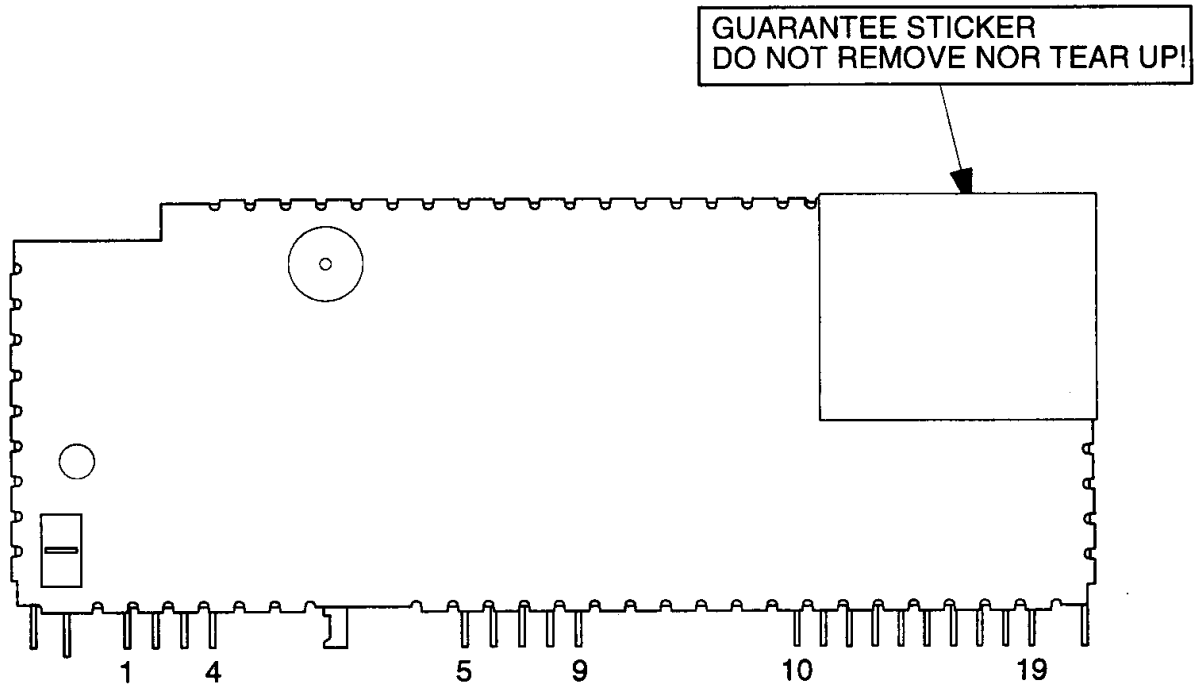

Connections

1	AM/FM Aerial input	10	Multiplex / RDS output signal
2	Ground	11	Unweighted level output
5	Inlock detector pin	12	I ² C SDA
6	Vcc 8.5V	13	I ² C SCL
7	Ground	14	SDS time constant pin
8	Vcc 5.0V	17	Ground
9	V reference	19	AM audio output

Quick reference data:

1) AM part

- Longwave/Mediumwave 144-1710 KHz (inclusive USA)
- Shortwave 5850-6250 KHz - 49 meter band
- AM double super concept
- AM IF1 10.7MHz
- AM IF2 450KHz
- First VCO frequency above input signal frequency
- Second X-tal oscillator frequency below IF1
- Usable sensitivity $\alpha 26$ dB MW = 14 μ V typ.

1) FM part

- FM 87.5 - 108MHz
- FM double super concept
- FM IF1 72.2MHz
- FM IF2 10.7MHz
- First VCO frequency above input signal frequency
- Second X-tal oscillator frequency below IF1
- Usable sensitivity $\alpha 26$ dB = 2.5 μ V typ.
- THD 1mV $\delta f = 75$ KHz = 0.5% typ
- Signal to noise ratio = 65dB typ
- Locktime synthesizer <2mSec

TUNER PART
[TU00]

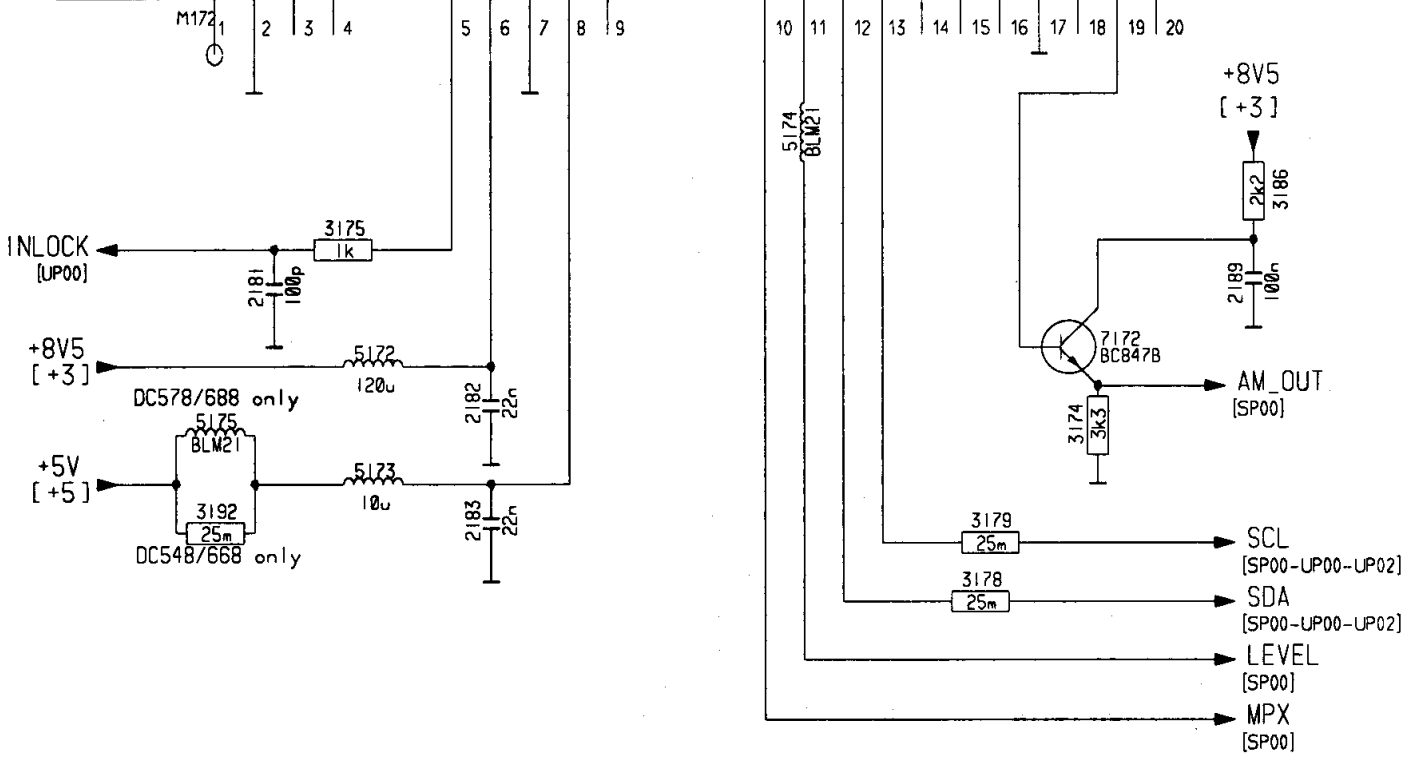
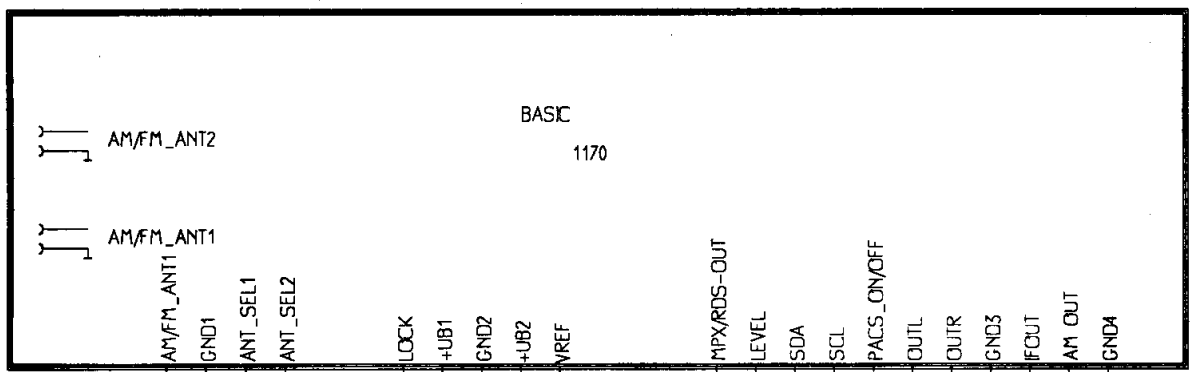

1st_PWR_ONG1 RESET_uC F1
 A4H16 SET_ON-OFF A16
 A5B1 V_LOW E1
 MUTE_ENABLEE1 V_LOW_uC F1
 POWER_SENSEC16
 P_A_MUTEK14

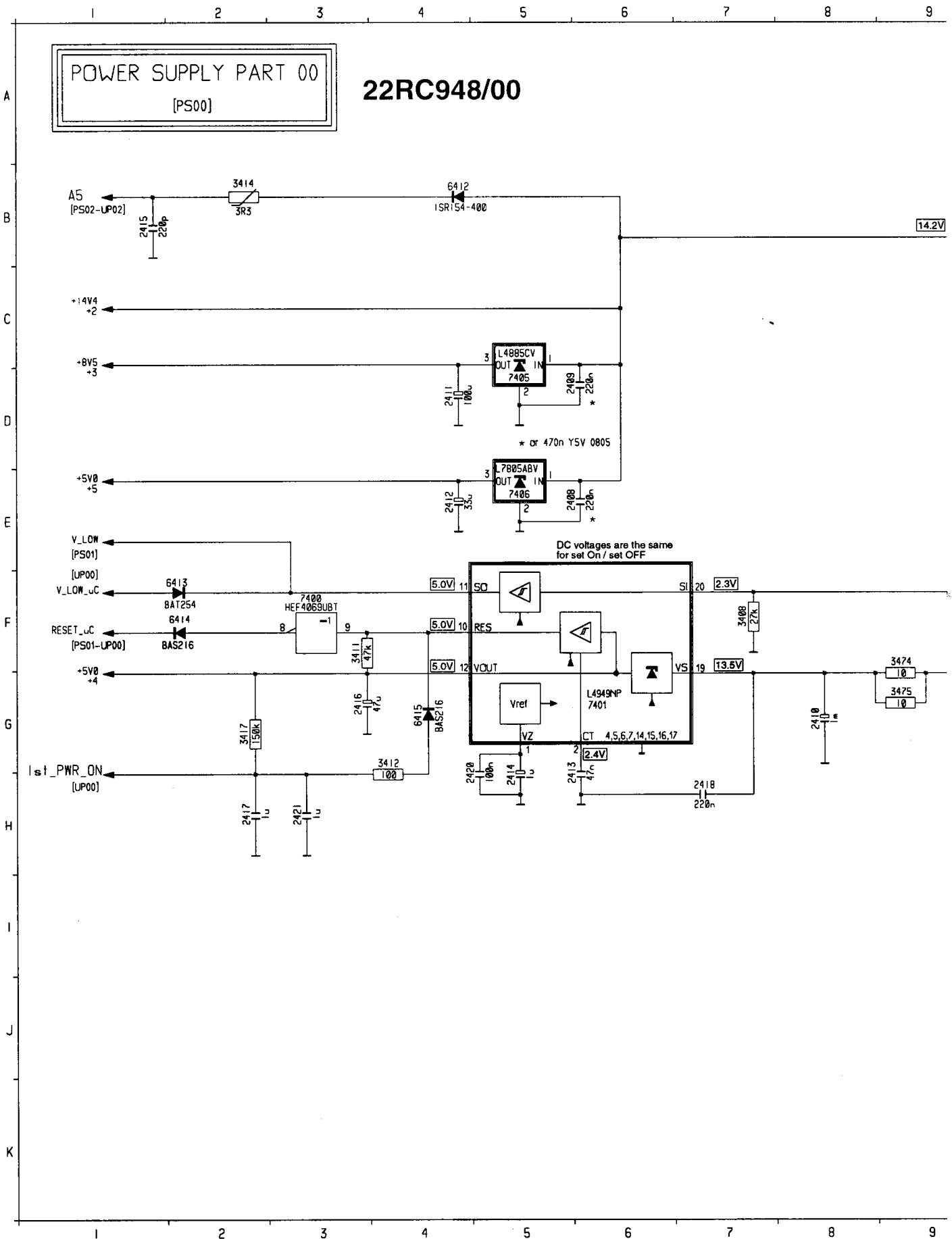

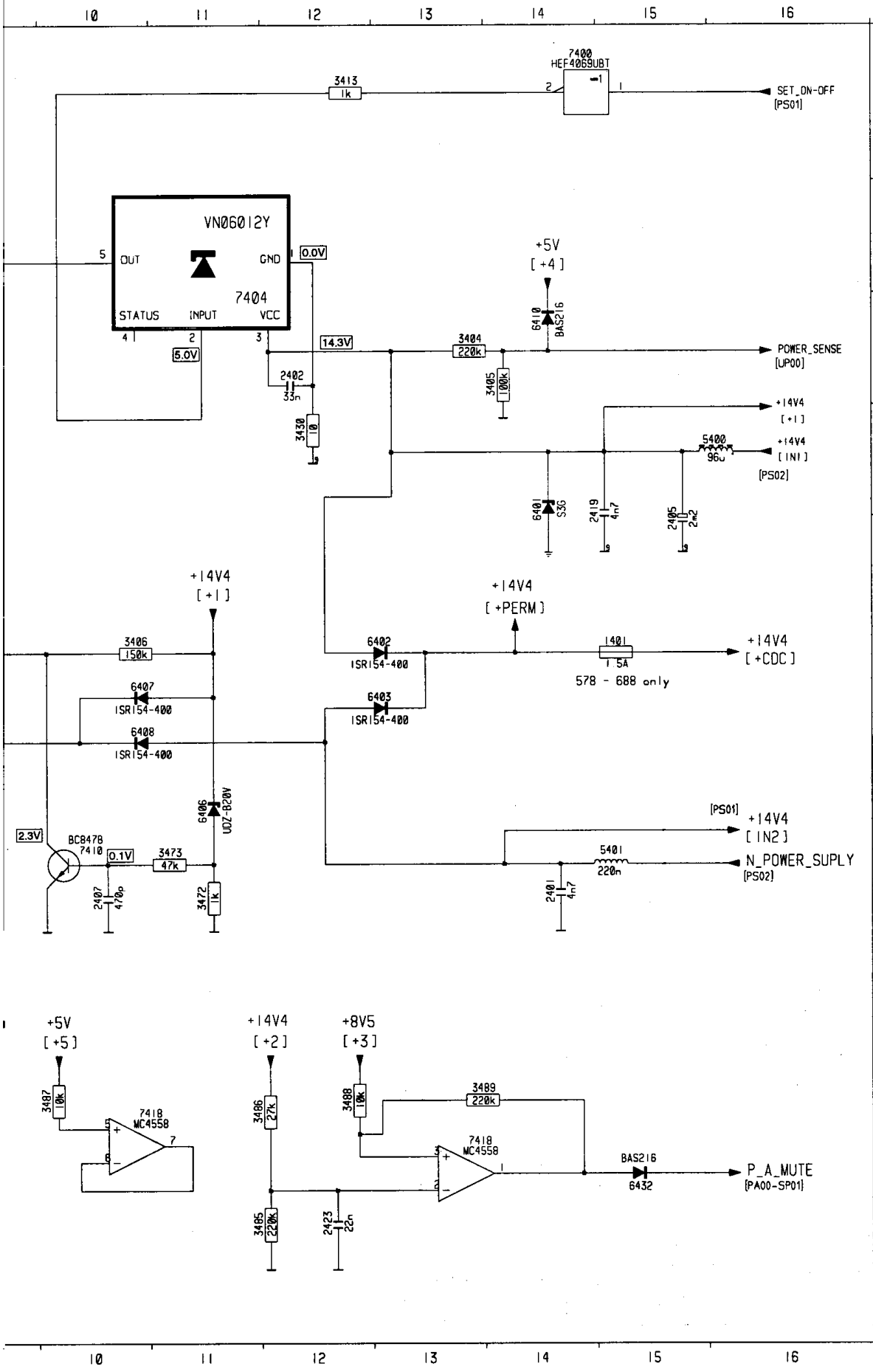

1401	F15
2401	H14
2402	C12
2405	E15
2407	H10
2408	E 6
2409	D 6
2410	G 8
2411	D 4
2412	E 4
2413	H 6
2414	H 5
2415	B 1
2416	G 3
2417	H 2
2418	H 7
2419	D15
2420	H 5
2421	H 3
2423	K12
3404	C13
3405	C14
3406	F10
3408	F 7
3411	F 3
3412	G 4
3413	A12
3414	B 2
3417	G 2
3430	D12
3472	H11
3473	H11
3474	F 9
3475	G 9
3485	K11
3486	J11
3487	J10
3488	J12
3489	J13
5400	D16
5401	H15
6401	D14
6402	F13
6403	F13
6406	G11
6407	F10
6408	F10
6410	C14
6411	E 2
6412	B 4
6413	F 2
6414	F 2
6415	G 4
6432	K15
7400	A14
7400	F 3
7401	G 6
7404	C12
7405	D 5
7406	E 5
7410	H10
7418	J13
7418	J11

CLOCKG6
 CLOCK_1HZG1
 DETACH_FRONTJ15
 EN_RESETB1
 IGNITIONE15
 NEWD1
 NO_POWER_SENSG15
 ON_OFF_SWJ15
 PLAY_LOADER.....J15
 RESET_uCF1
 SOLEN_EJECT.....K15
 V_LOWD10

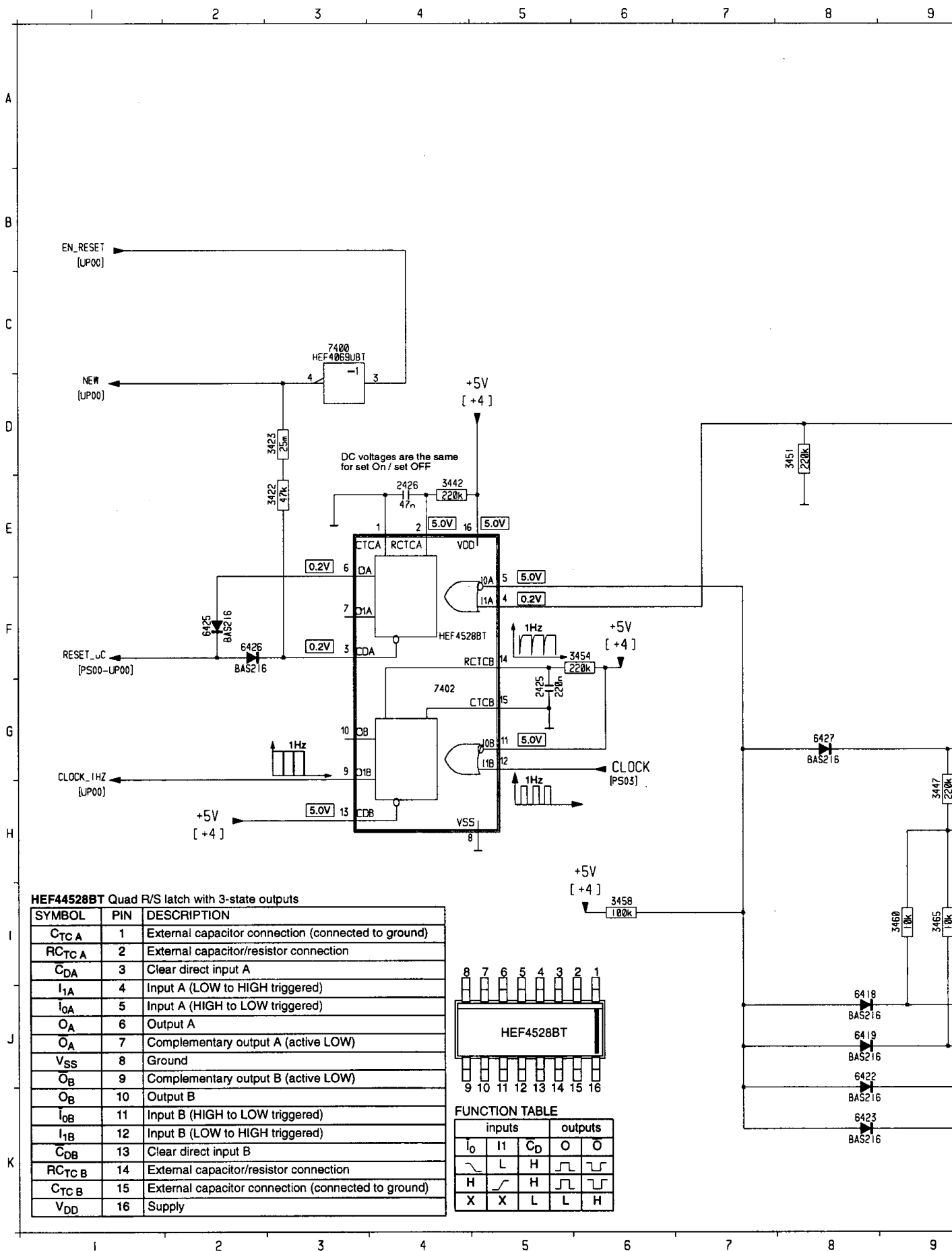

HEF4528BT Quad R/S latch with 3-state outputs

SYMBOL	PIN	DESCRIPTION
C _{TC A}	1	External capacitor connection (connected to ground)
R _{CTC A}	2	External capacitor/resistor connection
C _{DA}	3	Clear direct input A
I _{1A}	4	Input A (LOW to HIGH triggered)
I _{0A}	5	Input A (HIGH to LOW triggered)
O _A	6	Output A
O _A	7	Complementary output A (active LOW)
V _{SS}	8	Ground
O _B	9	Complementary output B (active LOW)
O _B	10	Output B
I _{0B}	11	Input B (HIGH to LOW triggered)
I _{1B}	12	Input B (LOW to HIGH triggered)
C _{DB}	13	Clear direct input B
R _{CTC B}	14	External capacitor/resistor connection
C _{TC B}	15	External capacitor connection (connected to ground)
V _{DD}	16	Supply

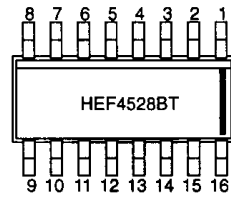

FUNCTION TABLE

inputs			outputs	
I ₀	I ₁	C _D	O	O
L	H	H	L	H
H	L	H	H	L
X	X	L	L	H

POWER SUPPLY PART 01
[PS01]

22RC948/00

2425	G 5
2426	E 4
2428	D 9
2429	G10
2432	J10
2433	J10
2434	F11
3422	E 3
3423	D 3
3432	I11
3433	I11
3442	E 4
3447	H 9
3451	D 8
3454	F 6
3458	I 6
3460	I 9
3463	I10
3464	I10
3465	I 9
3468	G14
3470	H12
3471	G12
6418	J 8
6419	J 8
6422	J 8
6423	K 8
6425	F 2
6426	F 2
6427	G 8
7400	C 3
7400	G11
7402	G 4

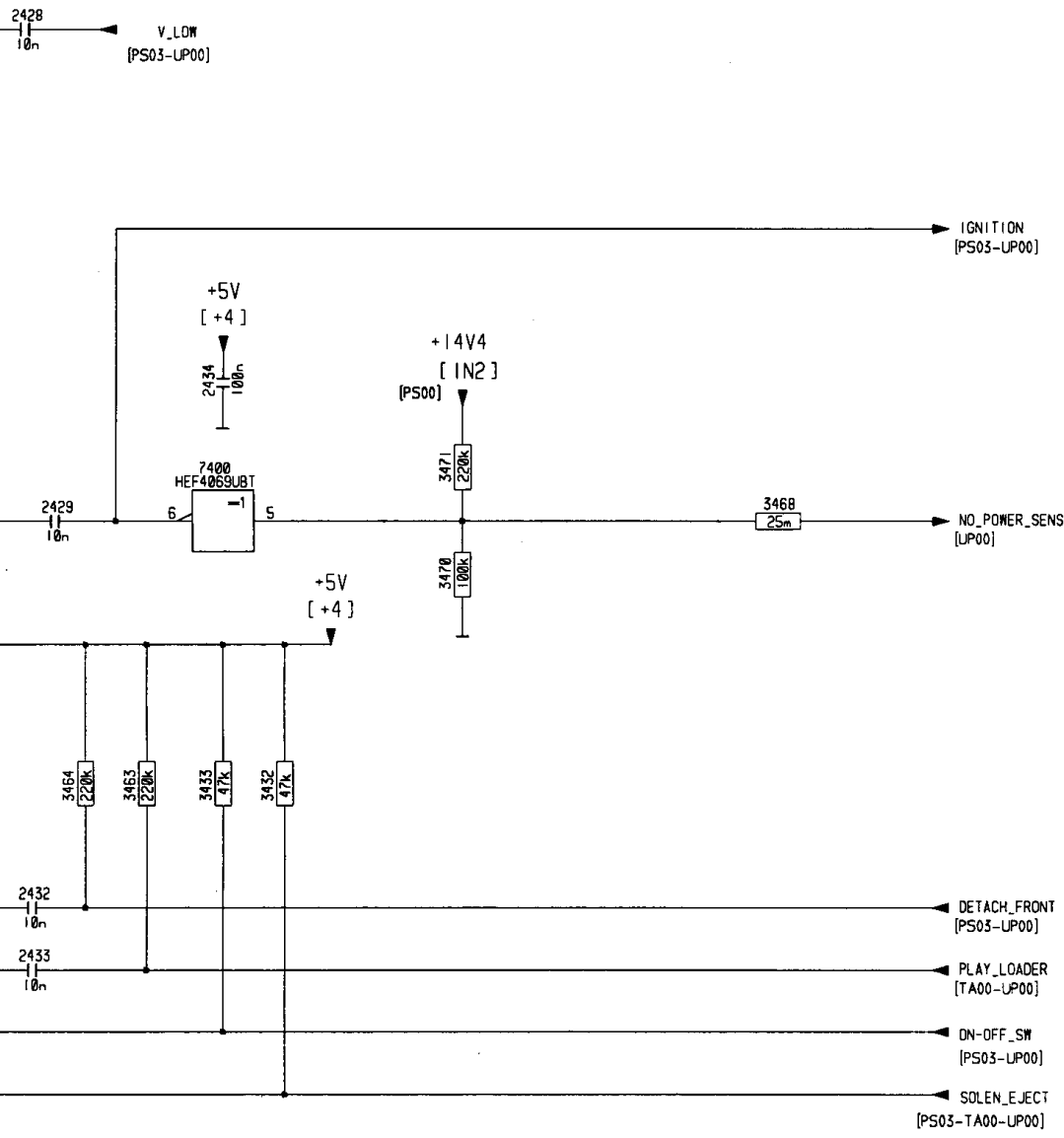

A
B
C
D
E
F
G
H
I
J
K

A1	B2/E7	B2	E8	B8	B8	TEL_MUTE
A2	F7/E2	B3	D8	N_POWER_SUPPLY	C6	
A3	F7/G1	B4	D8	REMOTE_B	G5	
A5	F8	B5	C8	REM_SUPPLY	F1	
A6	F6	B6	C8	SCL_G	F8	
B1	D8	B7	B8	SDA_G	G8	

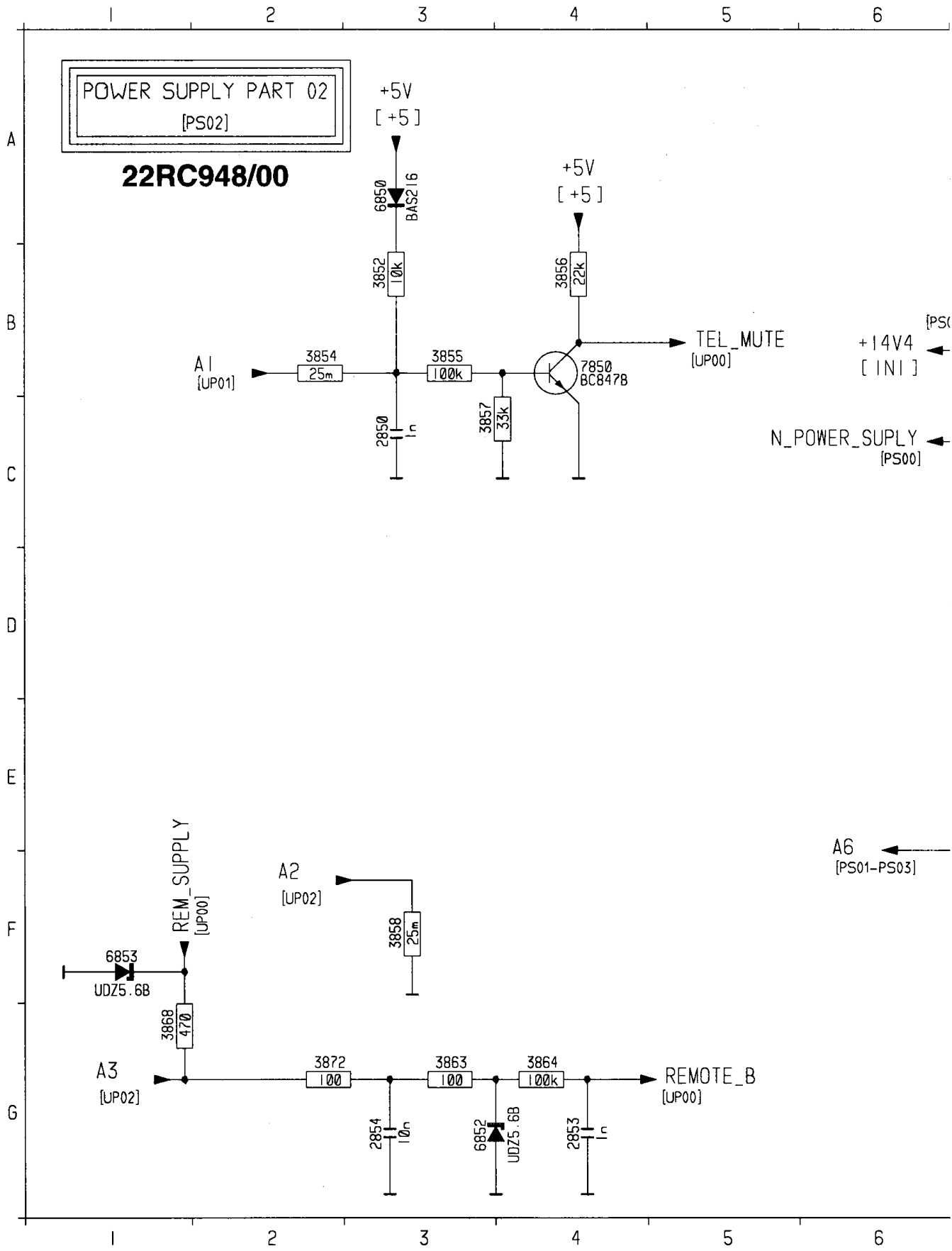

BLOCK CONNECTOR

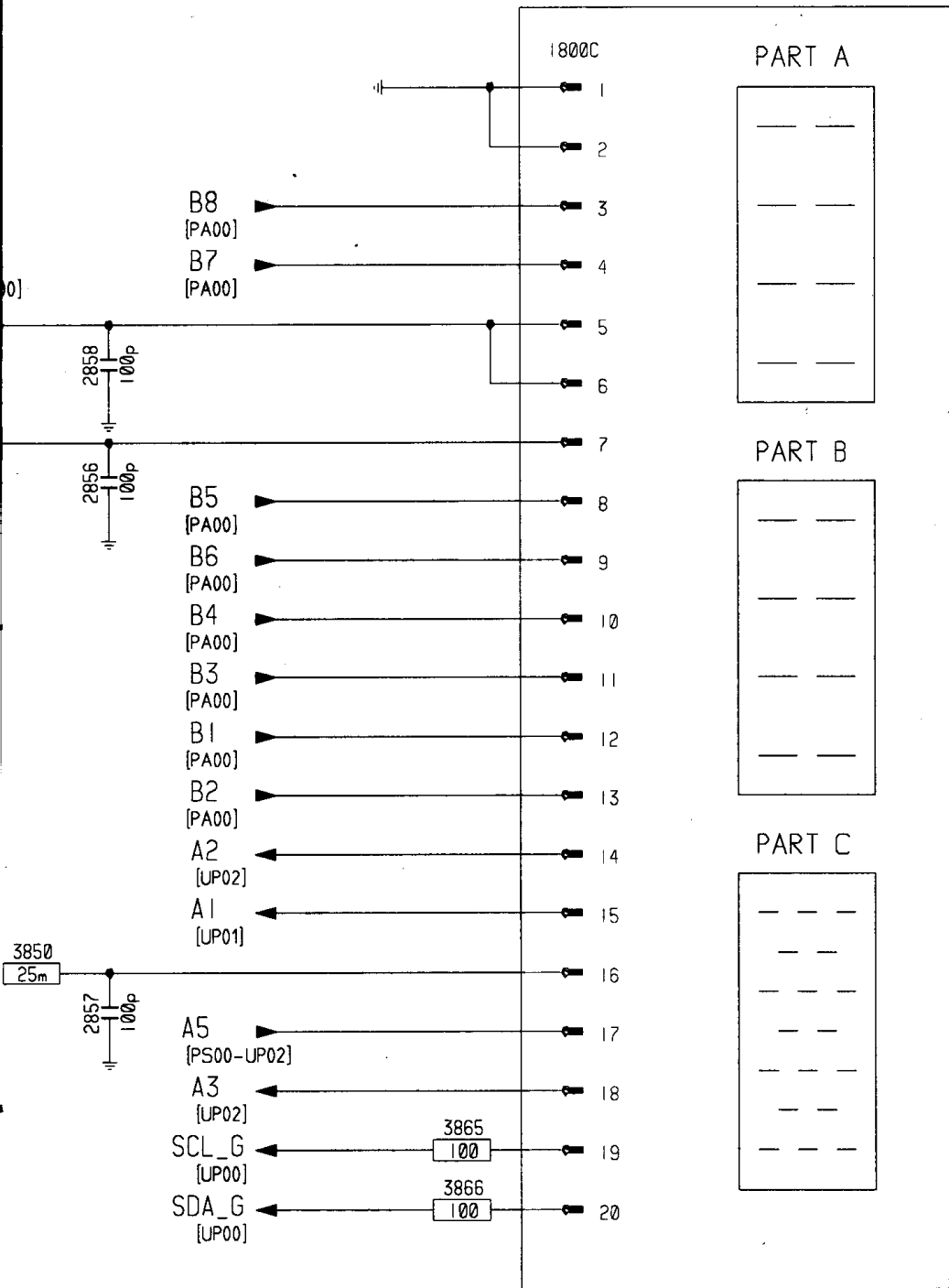

A	1800	A 9
	2850	C 3
	2853	G 4
	2854	G 3
	2856	C 7
	2857	F 7
	2858	B 7
	3850	E 7
	3852	B 3
	3854	B 2
	3855	B 3
B	3856	B 4
	3857	C 3
	3858	F 3
	3863	G 3
	3864	G 4
	3865	F 9
	3866	G 9
C	3868	G 1
	3872	G 2
	6850	A 3
	6852	G 3
	6853	F 1
	7850	B 4
D		
E		
F		
G		

7 8 9 10 11

A6 A1 PWM1 G1
 BL_ON-OFF J6 SCL_F D13
 CLOCK F7 SDA_F E13
 DETACH_FRONT I10 SOLEN_EJECT G10
 KEYBOARD_INT E12 V_LAMP C5/I13
 ON-OFF_SW G10 V_LED A5/H13

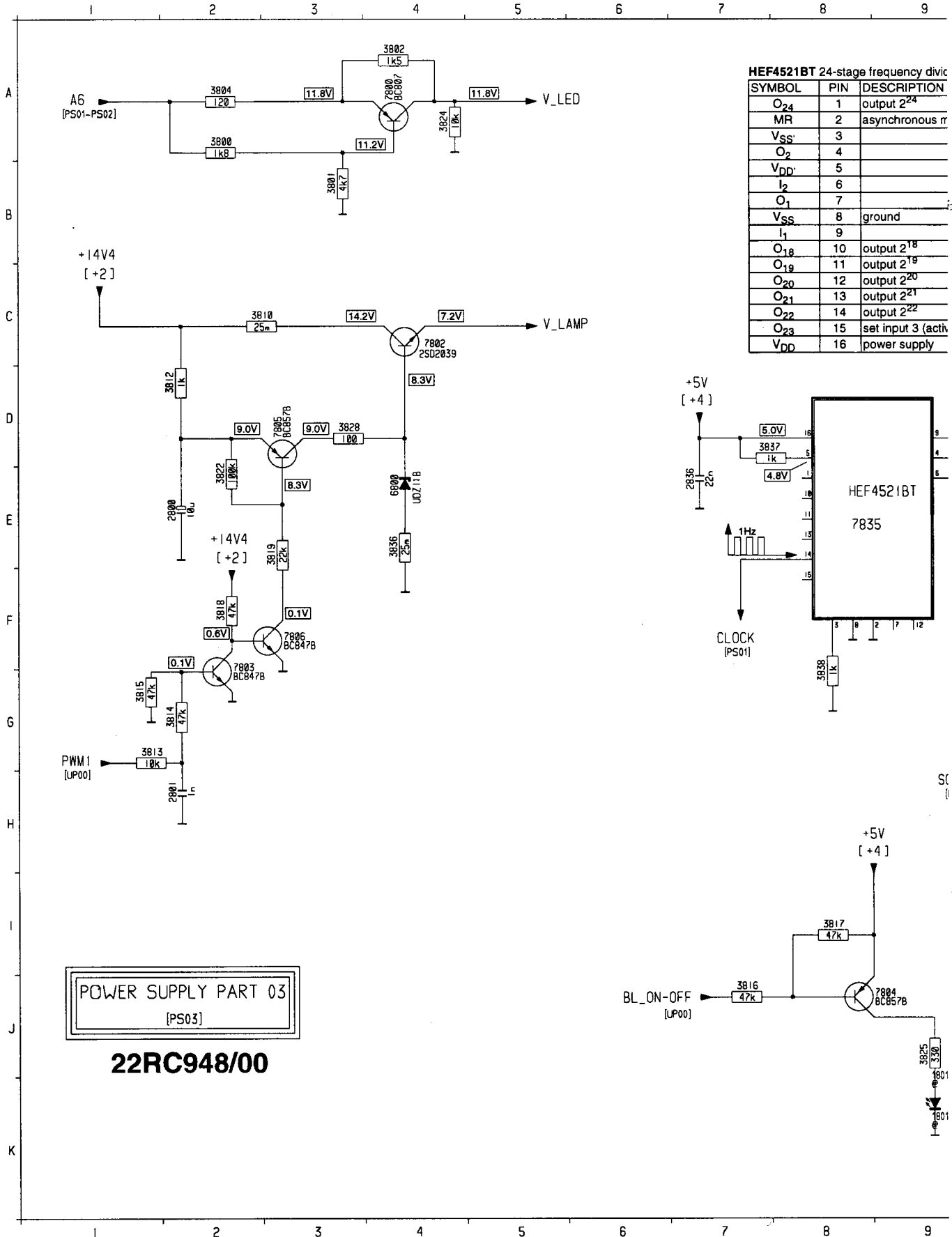

HEF4521BT 24-stage frequency divider

SYMBOL	PIN	DESCRIPTION
O ₂₄	1	output 2 ²⁴
MR	2	asynchronous reset
V _{SS}	3	
O ₂	4	
V _{DD}	5	
I ₂	6	
O ₁	7	
V _{SS}	8	ground
I ₁	9	
O ₁₈	10	output 2 ¹⁸
O ₁₉	11	output 2 ¹⁹
O ₂₀	12	output 2 ²⁰
O ₂₁	13	output 2 ²¹
O ₂₂	14	output 2 ²²
O ₂₃	15	set input 3 (active low)
V _{DD}	16	power supply

POWER SUPPLY PART 03
[PS03]

22RC948/00

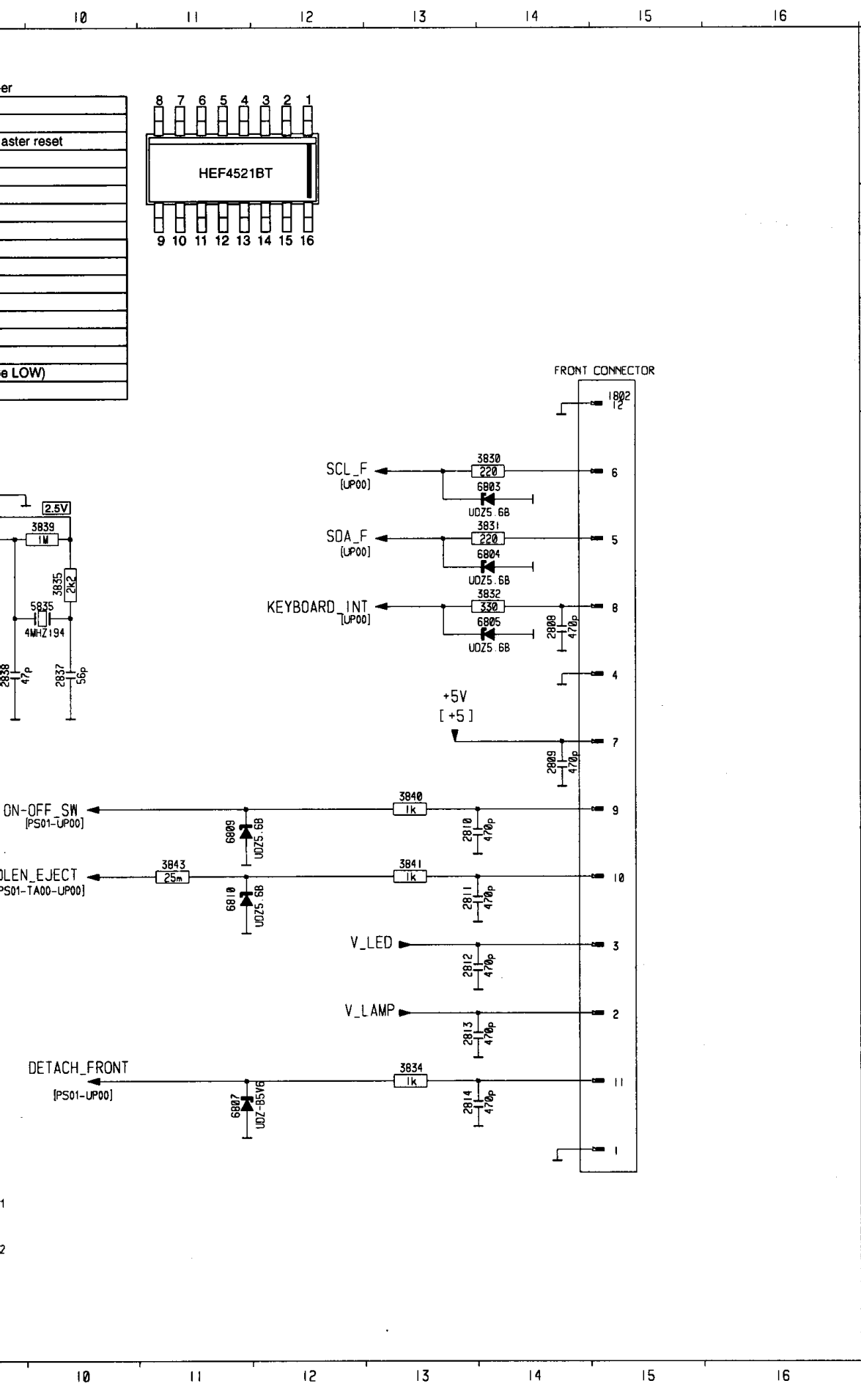

1801	K 9
1802	C15
2800	E 2
2801	H 2
2808	E14
A	
2809	G14
2810	G13
2811	H13
2812	H13
2813	I13
2814	J13
B	
2836	E 7
2837	F10
2838	F 9
3800	A 2
3801	B 3
3802	A 4
3804	A 2
C	
3810	C 3
3812	D 2
3813	G 1
3814	G 2
3815	G 1
3816	J 7
D	
3817	I 8
3818	F 2
3819	E 3
3822	E 2
3824	A 4
3825	J 9
E	
3828	D 3
3830	D14
3831	E14
3832	E14
3834	I13
F	
3835	E10
3836	E 4
3837	D 7
3838	G 8
3839	E10
3840	G13
G	
3841	H13
3843	H11
5835	E10
6800	E 4
6803	D14
6804	E14
6805	E14
H	
6807	J11
6809	G11
6810	H11
7800	A 4
7802	C 4
I	
7803	G 2
7804	J 9
7805	D 3
7806	F 3
7835	E 8
J	
K	

AM_OUT.....G3	CLOCK_RDSJ8	INREFI2	POMD17
CD_CL.....I10	DATA_RDSK10	LEVELD3	RDS_HOLDA11
CD_DATA.....I10	FLE17	MPXH4	RDS_MUTEA11
CD_LI6	FRE17	MPX_RDSC3	RLF17
CD_RJ6	INLI2	N_RESET_DEVI13	RRG17
CD_WS.....I10	INRJ2	PAUSEA12	SCLI12

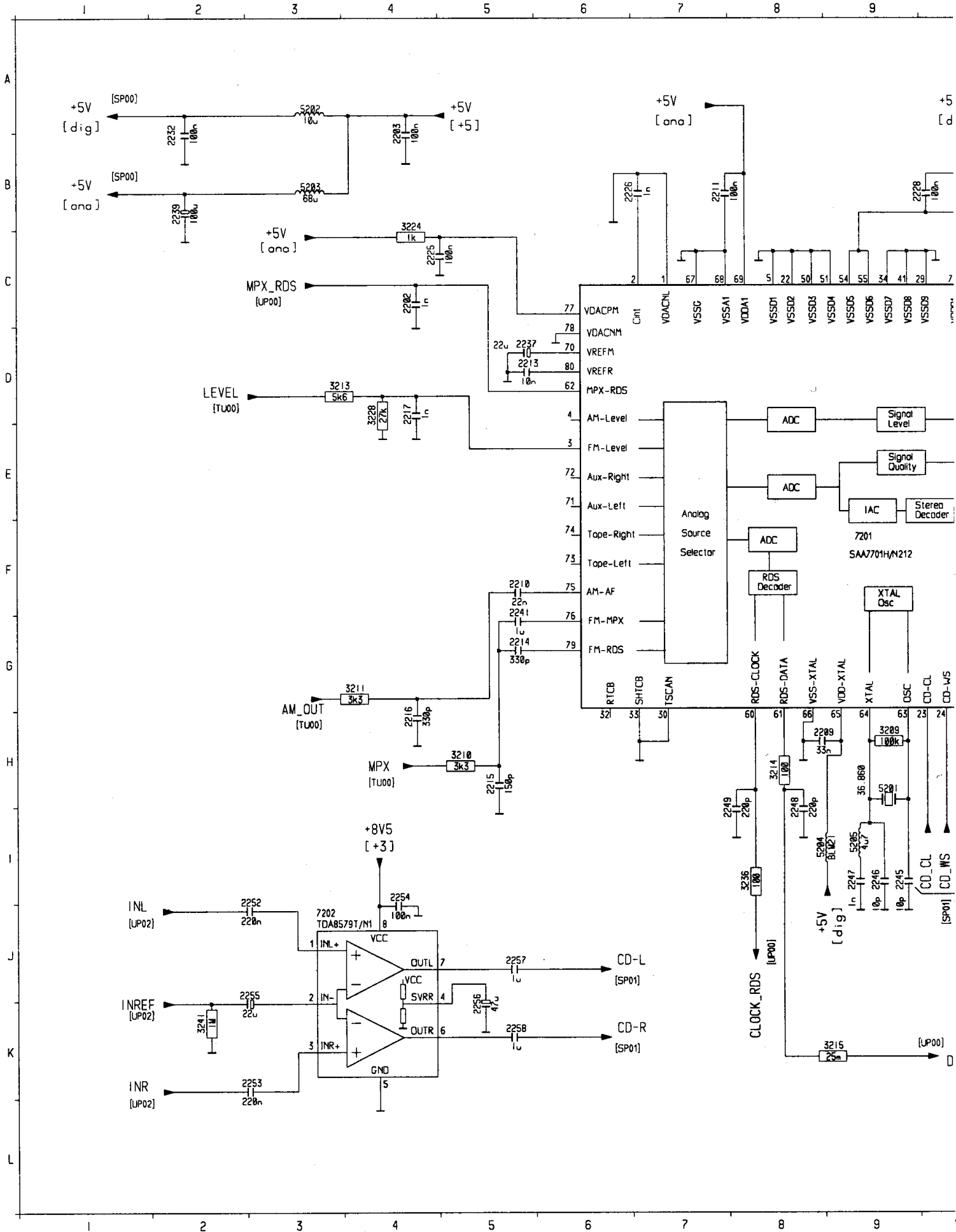

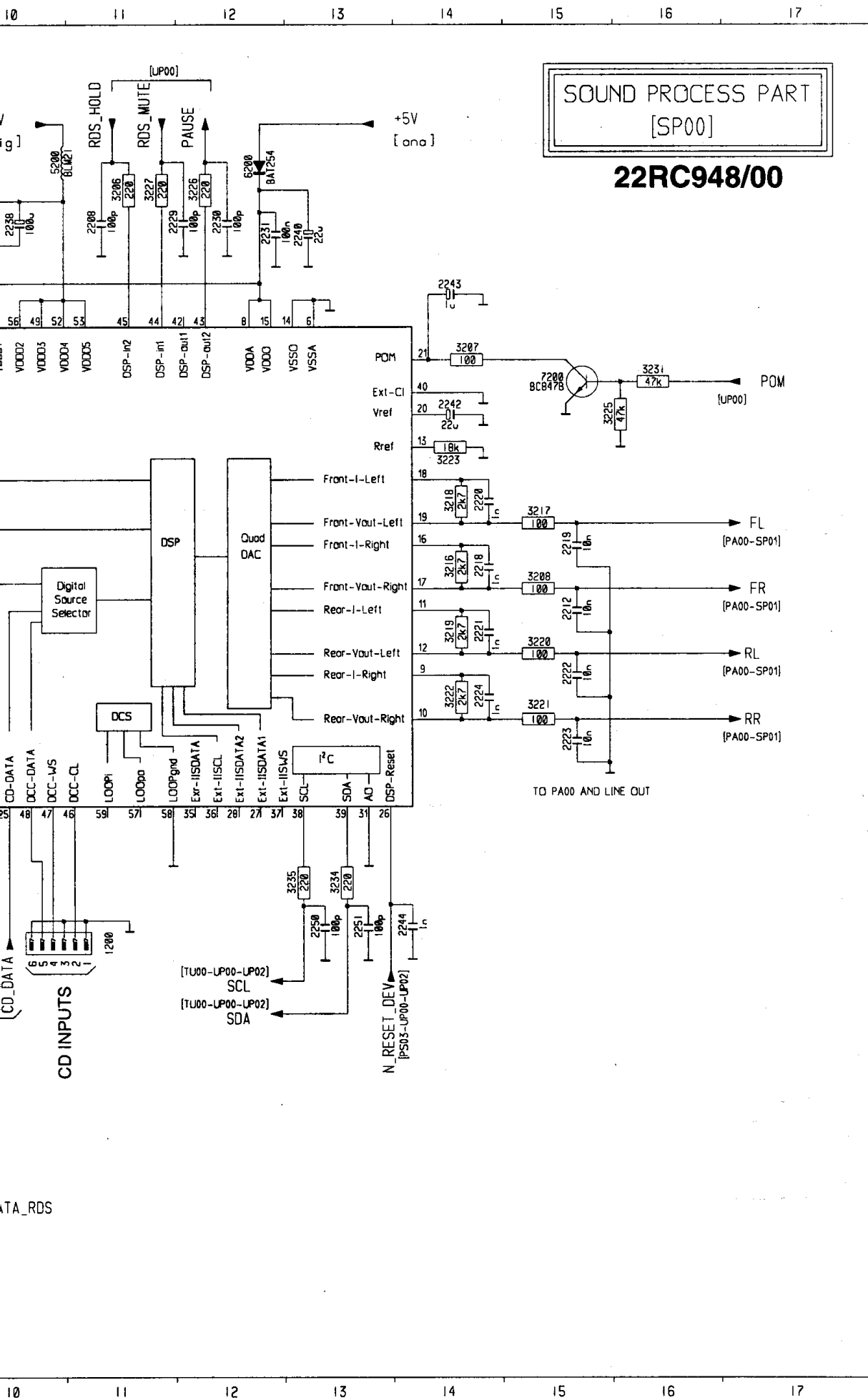

SOUND PROCESS PART
[SP00]

22RC948/00

A	1200	I 1	3221	G 15
	2202	C 4	3222	F 14
	2203	B 4	3223	D 14
	2208	H 1	3224	B 4
	2209	H 8	3225	D 15
	2210	F 5	3226	B 12
	2211	B 7	3227	B 11
	2212	F 15	3228	D 4
	2213	D 5	3231	C 16
	2214	G 5	3234	H 13
B	2215	H 5	3235	H 13
	2216	H 4	3236	I 8
	2217	D 4	3241	K 2
	2218	E 14	5200	B 10
	2219	E 15	5201	H 9
C	2220	E 14	5202	A 3
	2221	F 14	5203	B 3
	2222	F 15	5204	I 8
	2223	G 15	5205	I 8
	2224	F 14	6200	B 12
D	2225	C 4	7200	D 15
	2226	B 7	7201	F 9
	2228	B 10	7202	J 3
	2229	B 12		
	2230	B 12		
E	2231	B 12		
	2232	B 2		
	2237	D 5		
	2238	B 10		
	2239	B 2		
F	2240	B 13		
	2241	G 5		
	2242	D 14		
	2243	C 14		
	2244	I 14		
G	2245	I 9		
	2246	I 9		
	2247	I 9		
	2248	I 8		
	2249	I 8		
H	2250	I 13		
	2251	I 13		
	2252	J 3		
	2253	K 3		
	2254	I 4		
I	2255	J 3		
	2256	K 5		
	2257	J 5		
	2258	K 5		
	3206	B 11		
	3207	C 14		
	3208	E 15		
	3209	H 9		
	3210	H 5		
	3211	G 4		
J	3213	D 3		
	3214	H 8		
	3215	K 9		
	3216	E 14		
	3217	E 15		
K	3218	E 14		
	3219	F 14		
	3220	F 15		
L				

CD-R.....C10
 CD-L.....B10
 CD_CL.....C4
 CD_DATA.....B4
 CD_WS.....C4
 CDC_STBY.....A1
 FL.....E6

FRG6
 LO_FLD7
 LO_FRF7
 LO_RLD11
 LO_RRF11
 L_O_MUTEF5
 L_O_MUTEE7/G7

L_O_MUTEE11/G11
 P_A_MUTEF4
 RLE9
 RRG9

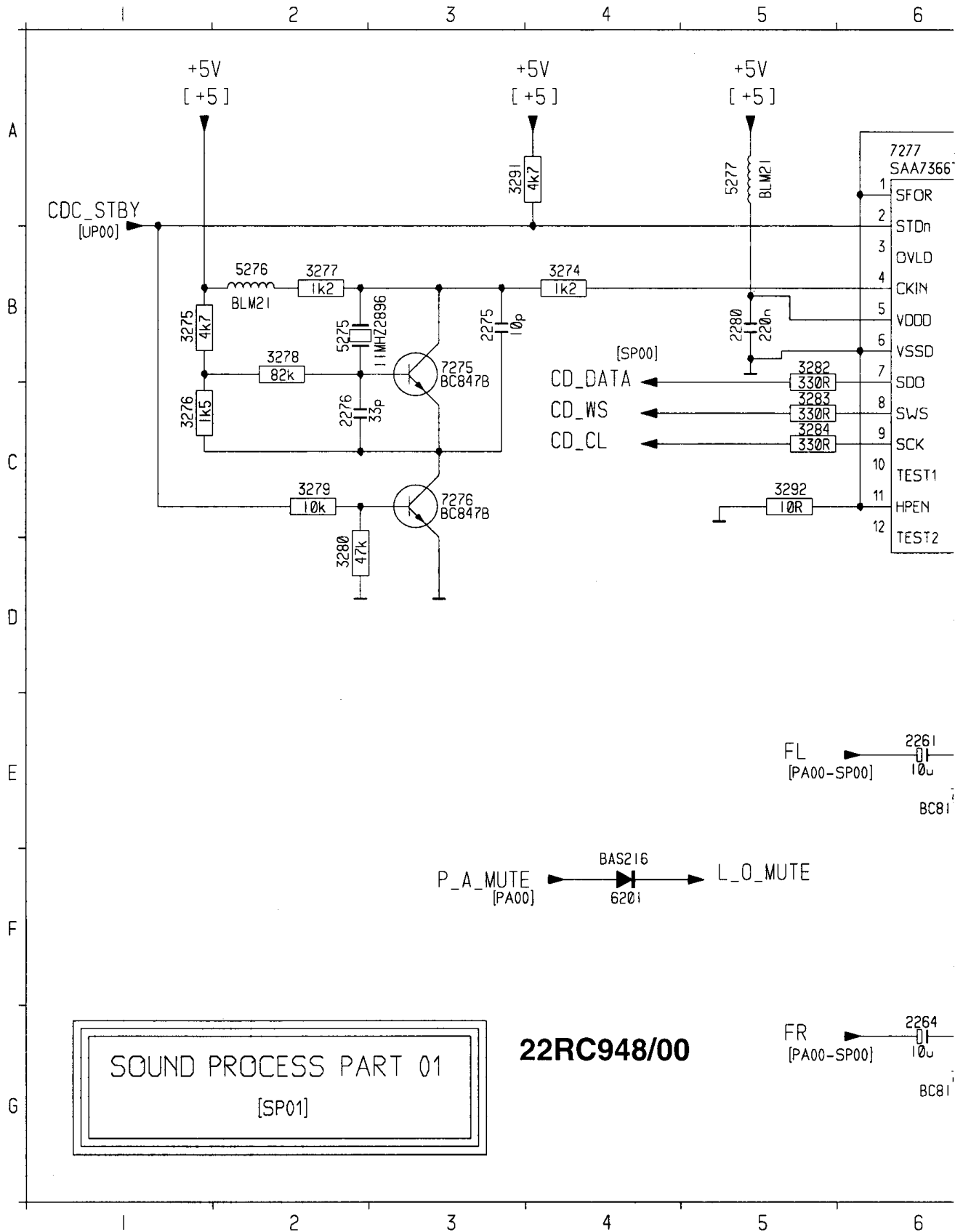

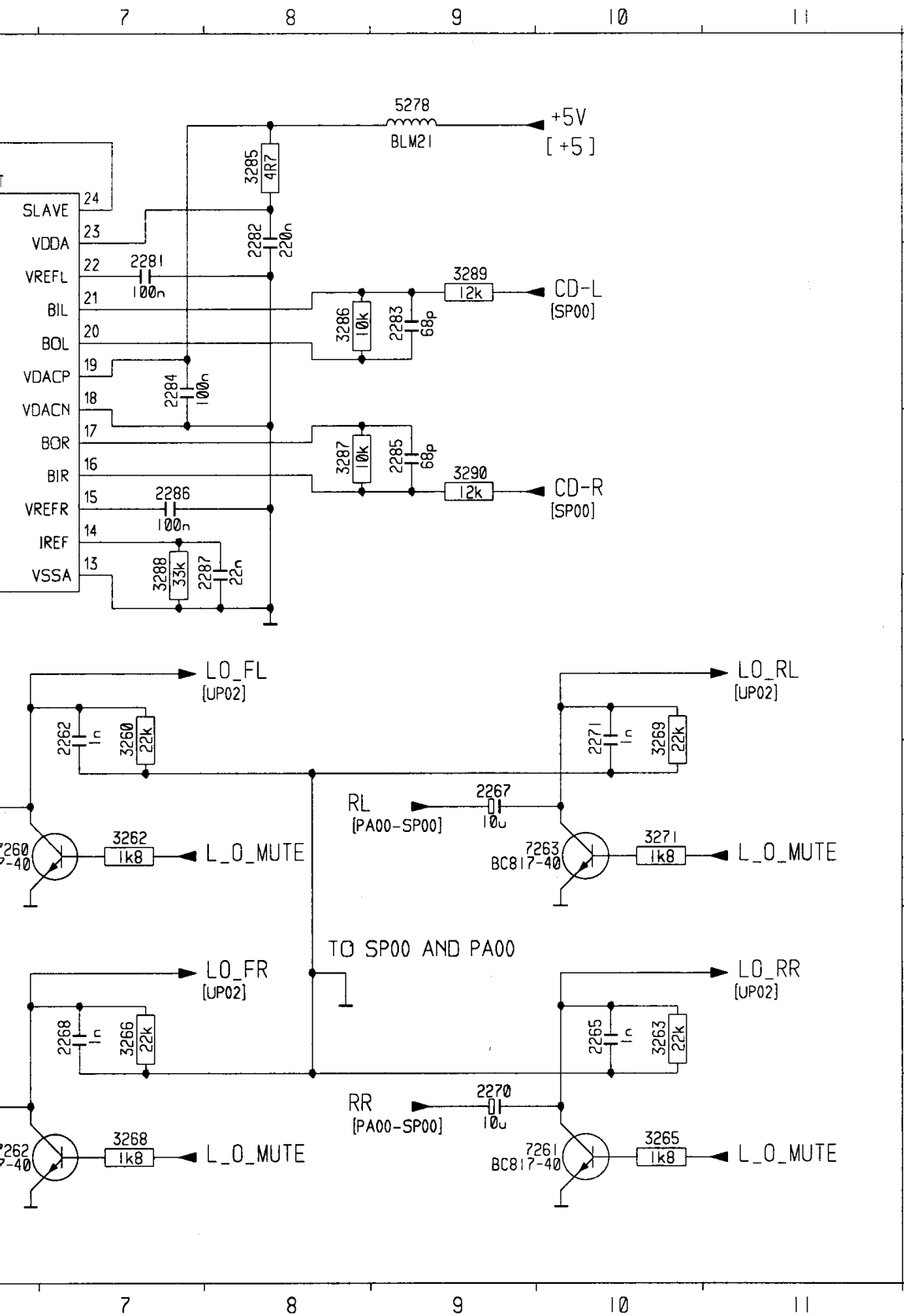

2261	E 6	5276	B 2
2262	D 7	5277	A 5
2264	G 6	5278	A 9
2265	F 10	6201	F 4
2267	E 9	7260	E 6
2268	F 7	7261	G 10
2270	G 9	7262	G 6
2271	D 10	7263	E 10
2275	B 3	7275	B 3
2276	C 2	7276	C 3
2280	B 5	7277	A 6
2281	B 7		
2282	A 8		
2283	B 9		
2284	B 7		
2285	C 9		
2286	C 7		
2287	C 8		
3260	D 7		
3262	E 7		
3263	F 10		
3265	G 10		
3266	F 7		
3268	G 7		
3269	D 10		
3271	E 10		
3274	B 4		
3275	B 1		
3276	C 1		
3277	B 2		
3278	B 2		
3279	C 2		
3280	D 2		
3282	B 5		
3283	C 5		
3284	C 5		
3285	A 8		
3286	B 8		
3287	C 8		
3288	C 7		
3289	B 9		
3290	C 9		
3291	A 3		
3292	C 5		
5275	B 2		

1st_PWR_ON.....G10	DATA_RDS.....H10	IGNITION.....G2	NEW.....D1/E10	POM.....
BL_ON-OFF.....I1	DETACH_FRONT.....J2	INLOCK.....J9	NO_POWER_SENS.....I2	POWERF.....
BUS_INT.....F1	EN_RESET.....J10	KEYBOARD_INT.....H1	N_RESET_DEV.....I12	POWERF.....
CDC_STBY.....J10	GALA_CD_MRQ.....F2	ME_FE_RES.....G9	ON-OFF_SW.....G2	PWM1.....
CLOCK_1HZ.....H2	I2C_SWITCH1.....H9/B17	MOX_RDS.....H9	PAUSE.....I10	RDS_H.....
CLOCK_RDS.....H9	I2C_SWITCH2.....H10/C17	MOT_DATA.....K9	PLAY_LOADER.....G1	RDS_M.....

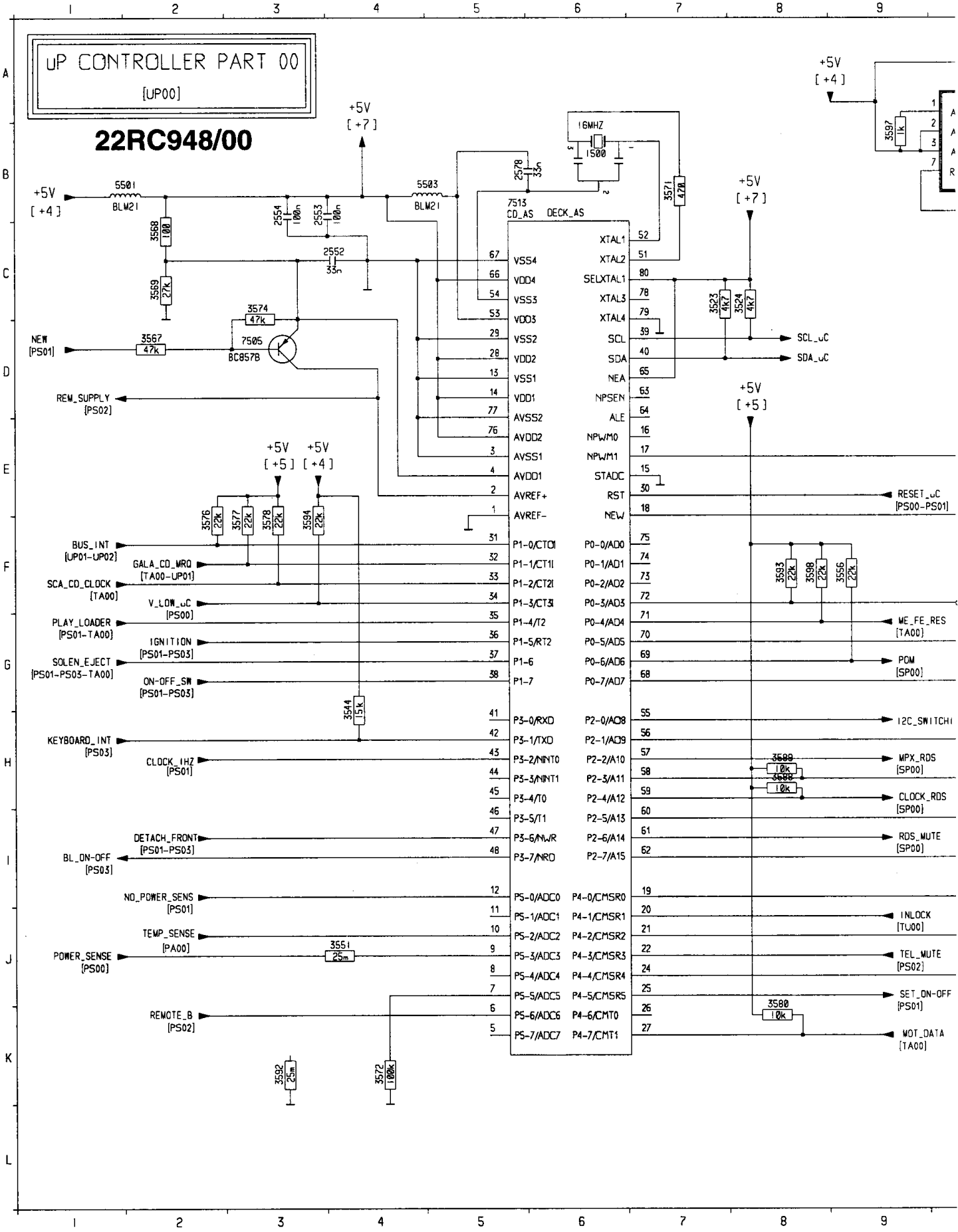

.....G9	REMOTE_B.....K2	SCL_G.....D13	SET_ON-OFF.....J9
R_MUTE.....G10	REM_SUPPLY.....D1	SCL_uC.....D8/D15	SOLENEJECT.....G1
R_SENS.....J1	RESET_uC.....E9/C17	SDA.....B12	TEL_MUTE.....J9
.....E10	SCA_CD_CLOCK.....F1	SDA_F.....B13	TEMP_SENSE.....J2
OLD.....I10	SCL.....C12	SDA_G.....B13	TRACK_DEEM.....F10
MUTE.....I9	SCL_F.....C13	SDA_uC.....D8/A15	V_LOW_uC.....F2

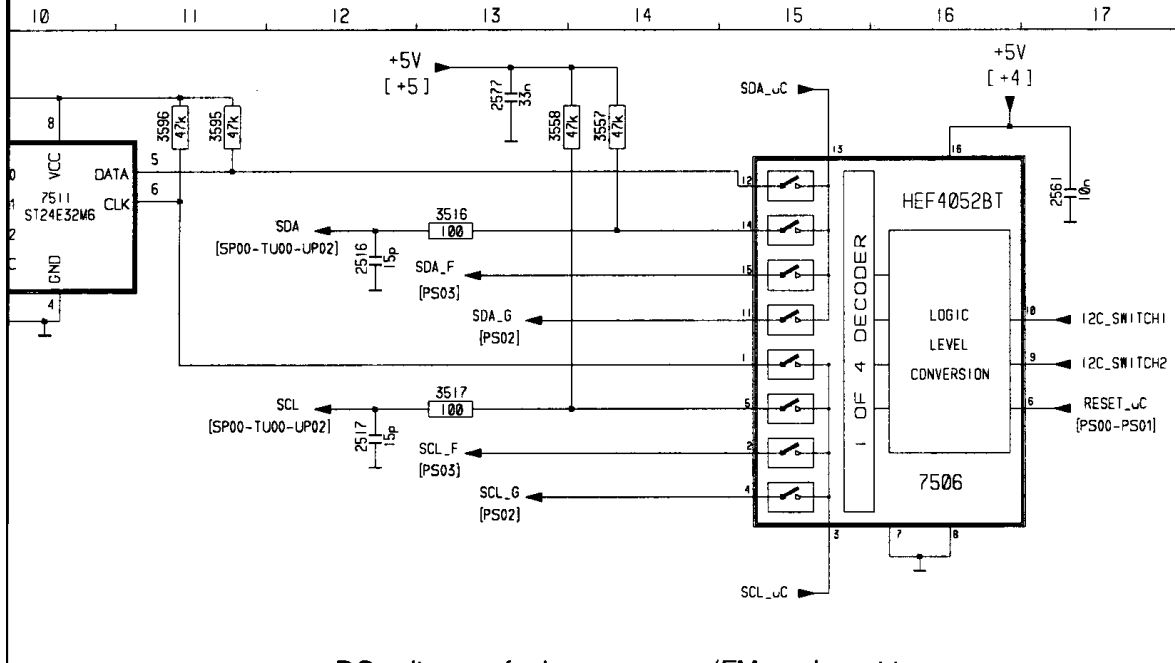

1500	B 6	3576	F 2
2516	B12	3577	F 3
2517	C12	3578	F 3
2552	C 4	3580	K 8
A 2553	B 3	3581	K 9
2554	B 3	3588	H 8
2561	B17	3589	H 8
2577	A13	3592	K 3
2578	B 5	3593	F 8
3516	B13	3594	F 3
B 3517	C13	3595	A11
3523	C 7	3596	A11
3524	C 8	3597	B 9
3544	H 4	3598	F 8
		5501	B 2
C 3551	J 4	5503	B 5
3556	F 9	7400	I11
3557	A14	7505	D 3
3558	A13	7506	D16
3567	D 2	7511	C10
3568	C 2	7513C	B 5
3569	C 2		
D 3571	B 7		
3572	K 4		
3574	C 3		

DC voltages of microprocessor (FM mode, set 1)

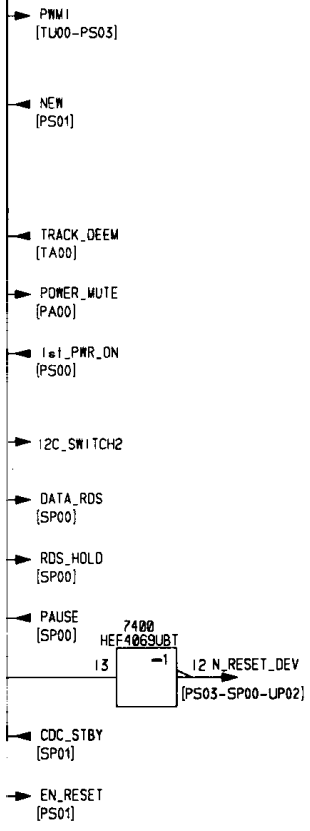

1	0.0V GND	41	N.C.
2	4.8V	42	5.0V \square WHEN ANY KEY PRESSED
3	0.0V GND	43	5.0V \square 1Hz
4	5.0V VDD	44	N.C.
5	N.C.	45	N.C.
6	5.0V	46	N.C.
7	0.0V	47	0.0V - 5.0V WHEN FRONT DETACHED
8	N.C.	48	5.0V
9	4.5V	49	N.C.
10	0.7V	50	N.C.
11	N.C.	51	2.5V 16MHz
12	4.5V	52	2.1V 16MHz
13	0.0V GND	53	5.0V VDD
14	5.0V VDD	54	GND \square
15	0.0V GND	55	5.0V \square 1Hz
16	N.C.	56	0.0V
17	0.0V	57	0.0V
18	0.0V	58	DATA
19	0.0V	59	CLOCK RDS
20	5.0V LOCKED	60	5.0V
21	0.0V	61	5.0V
22	0.0V	62	0.0V
23	N.C.	63	N.C.
24	5.0V	64	N.C.
25	0.0V	65	5.0V
26	N.C.	66	5.0V VDD
27	5.0V	67	GND
28	5.0V VDD	68	5.0V
29	0.0V GND	69	0.0V
30	0.0V	70	5.0V
31	5.0V	71	0.0V
32	5.0V	72	5.0V
33	5.0V	73	N.C.
34	5.0V	74	N.C.
35	5.0V	75	N.C.
36	0.0V	76	5.0V VDD
37	5.0V	77	GND
38	5.0V \square WHEN ON/OFF KEY PRESSED	78	N.C.
39	SCL	79	0.0V GND
40	SDA	80	5.0V

INL.....	E9	LO_RR.....	A9
INR.....	E9	MRQ_D2B.....	B1
INREF_BCL.....	D9	RESET_DEV.....	B1
LO_FL.....	A9	SCL.....	D1
LO_FR.....	A9	SDA.....	D1
LO_RL.....	A9		

BUS ADAPTATOR CONTROL I2C/D2B FOR CD CHANGER

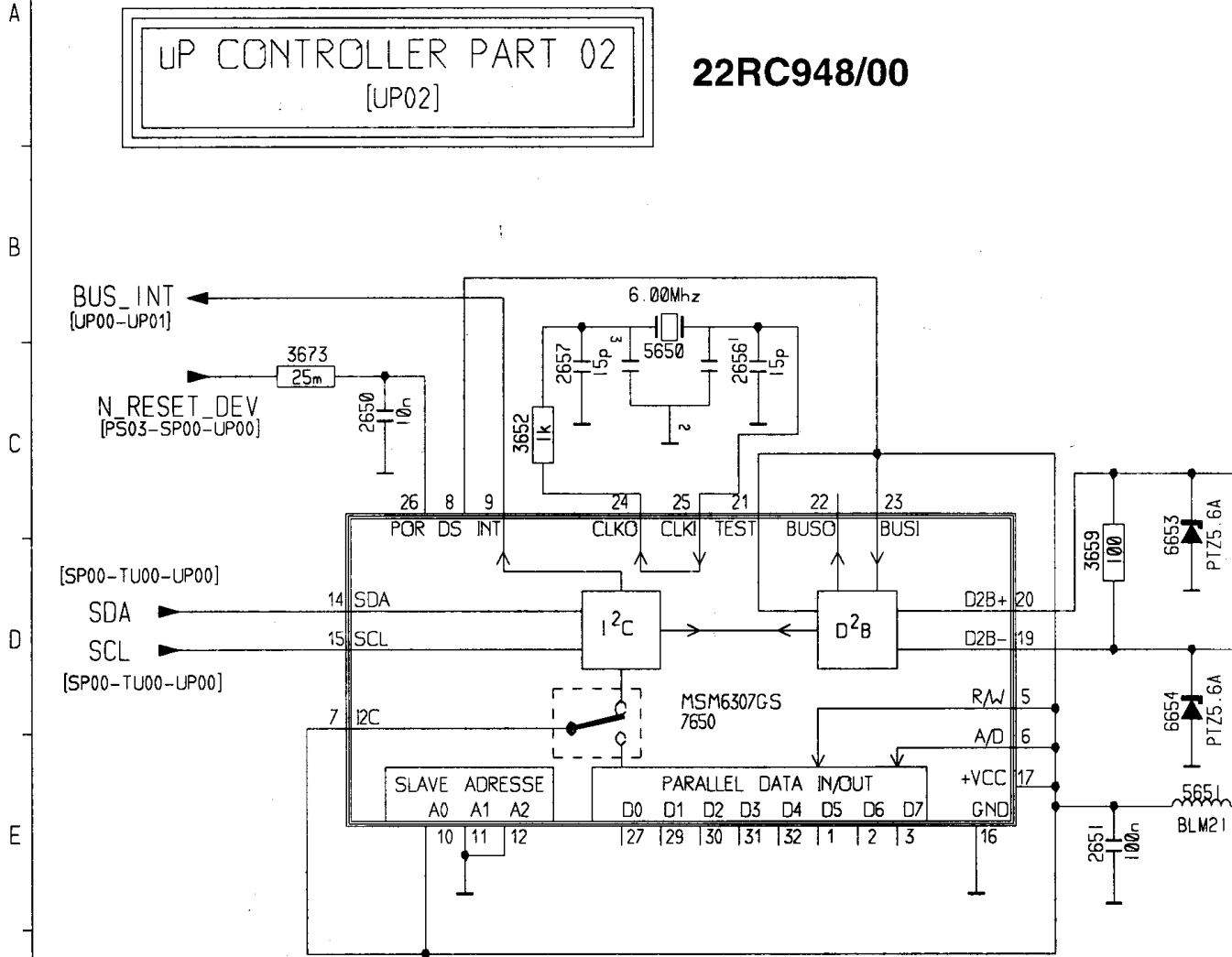

MSM6307GS D²B IC

SYMBOL	I/O	DESCRIPTION
POR	I	Power on - reset
R / W	I	Read / Write selector
DS	I	Data strobe to access data bus
A / D	I	Selects address or data on D0 ~ d7
SDA	I/O	I ² C data signal input / output
SCL	I/O	I ² C clock signal input / output
I2C	I	Selects I ² C or parallel interface
INT	O	Interrupt output
BUSIN	I	D2B input (TTL level)
BUSOUT	O	D2B output (TTL level)
DBN & DBP	I/Os	Differential D2B lines of the internal driver/receiver, to be terminated with 60Ω
TEST	I	Selects the test mode for factory purposes
6MCI	I	Clock input 6MHz resonator or X-TAL
6MCO	O	Clock output 6MHz resonator or X-TAL
D0 - D7	I/Os	8-bit bi-directional address or data bus
A0 - A2	I	Programmables I ² C slave addresses

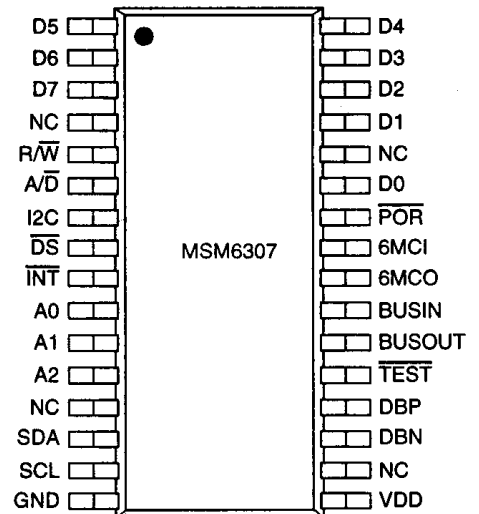

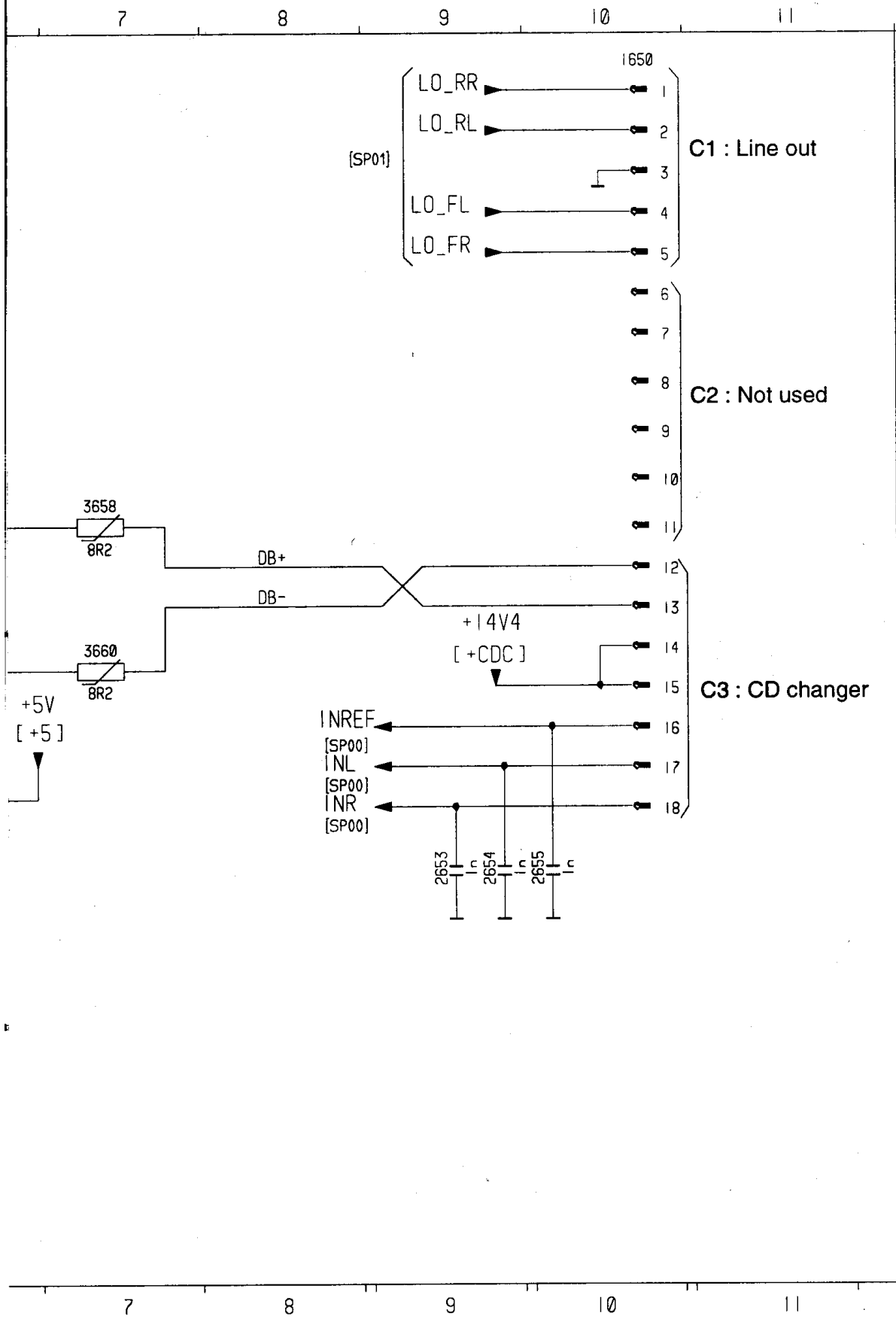

1650	A 10
2650	C 2
2651	E 6
2653	E 9
2654	E 9
2655	E 10
2656	C 4
2657	C 3
3652	C 3
3658	C 7
3659	D 6
3660	D 7
3673	C 2
5650	C 3
5651	E 6
6653	C 6
6654	D 6
7650	D 3

TAPE PART
 [TA00]

22RC948/00

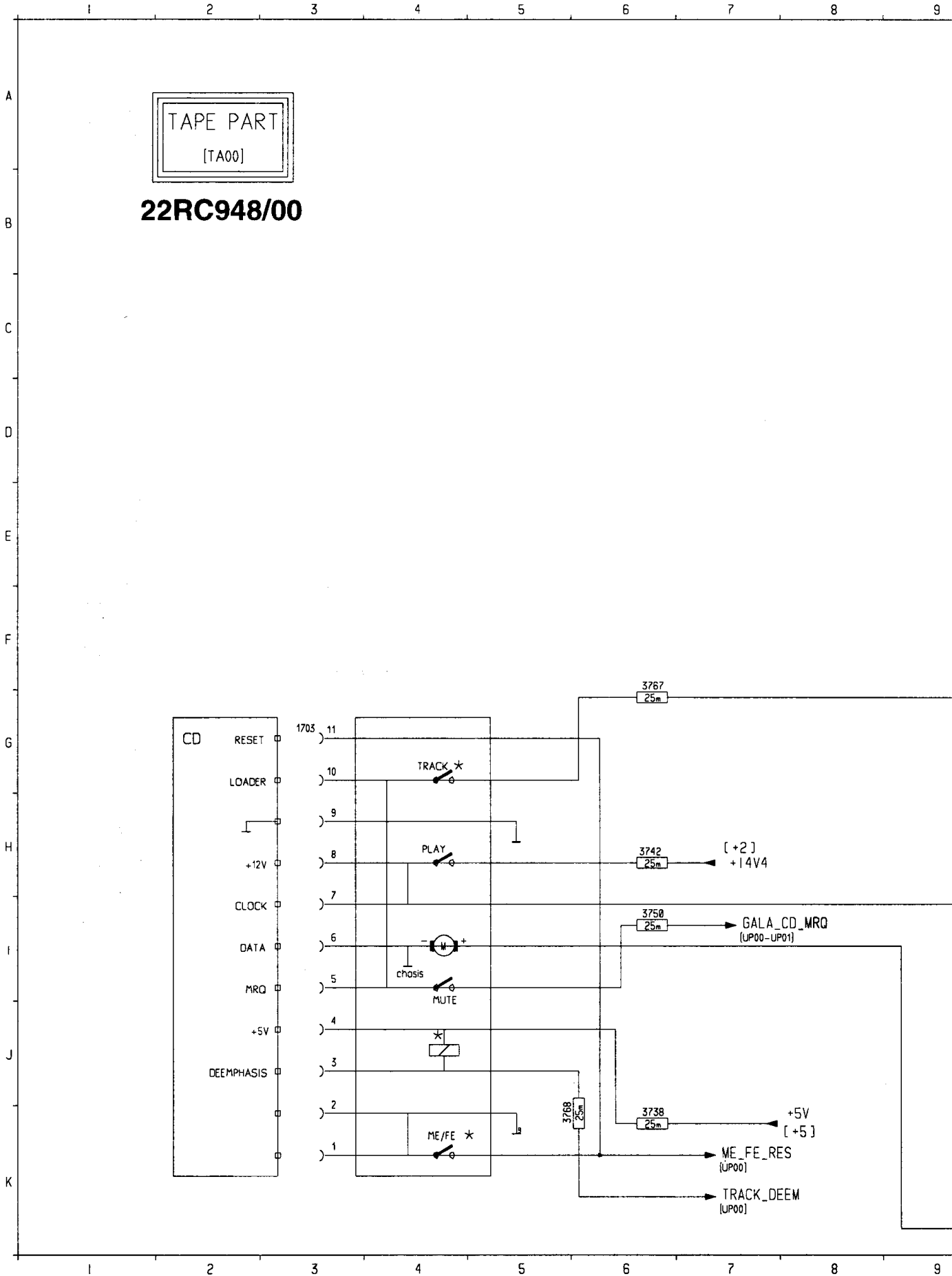

10 11 12 13 14 15 16

1703 G 3
3738 K 6
3742 H 6
3750 I 6
A 3757 H12
3767 F 6
3768 K 5
3769 K10
7400 K12

B

C

D

E

F

G

H

I

J

K

PLAY_LOADER
[PS01-UP00]

3757
25m
SCA_CD_CLOCK
[UP00]

7400
HEF4069UBT
-1
MGT_DATA
[UP00]

3769
25m

10 11 12 13 14 15 16

- | | | | | | |
|----------|-----|------------------|-----|------------------|----------|
| B1 | C16 | B7 | J16 | RL | J1 |
| B2 | C16 | B8 | J16 | RR | I1 |
| B3 | D16 | FL | H1 | SI | A5-A8-G8 |
| B4 | D16 | FR | J1 | TEMP_SENSE | G1 |
| B5 | I16 | PA_MUTE | C1 | | |
| B6 | I16 | POWER_MUTE | B1 | | |

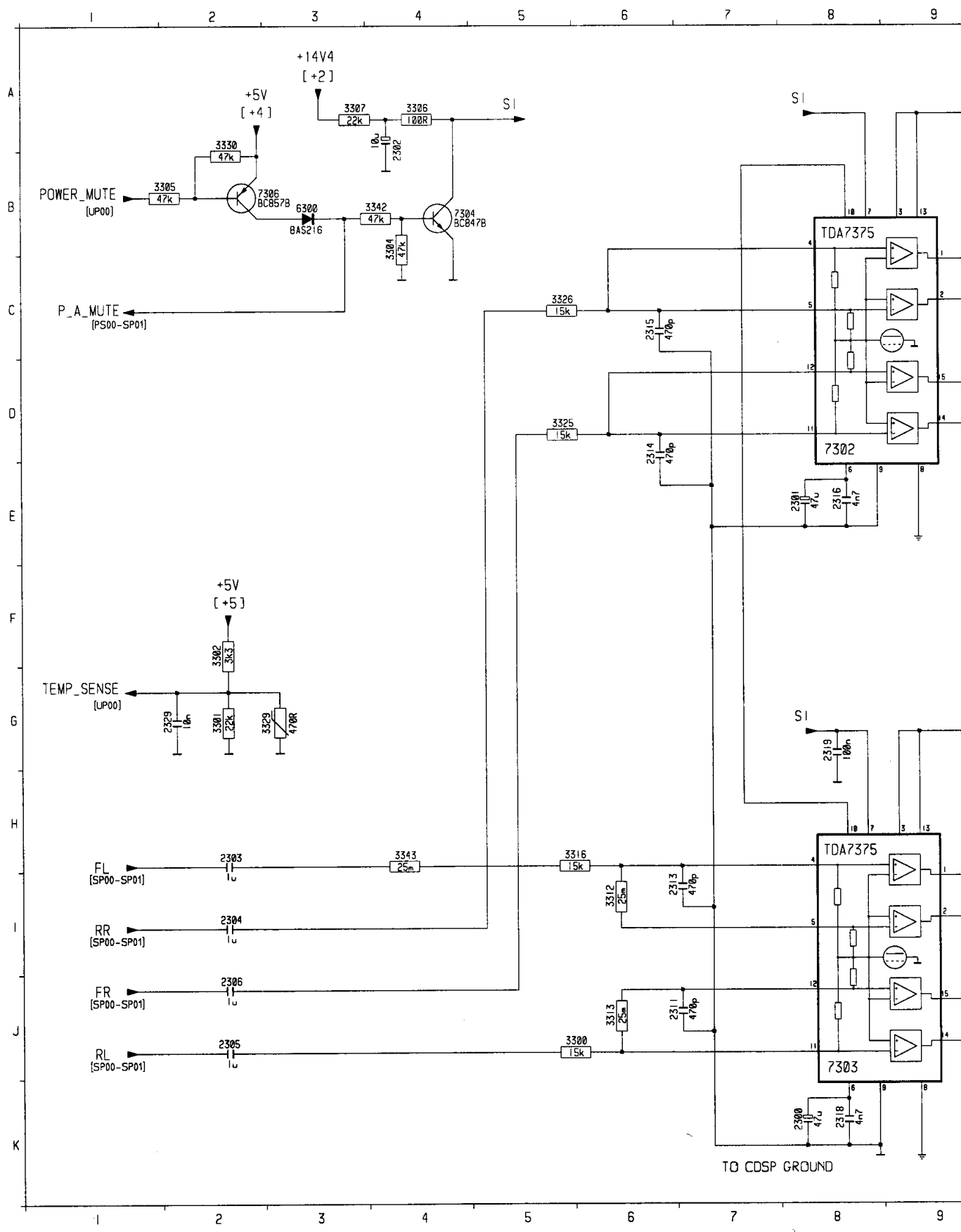

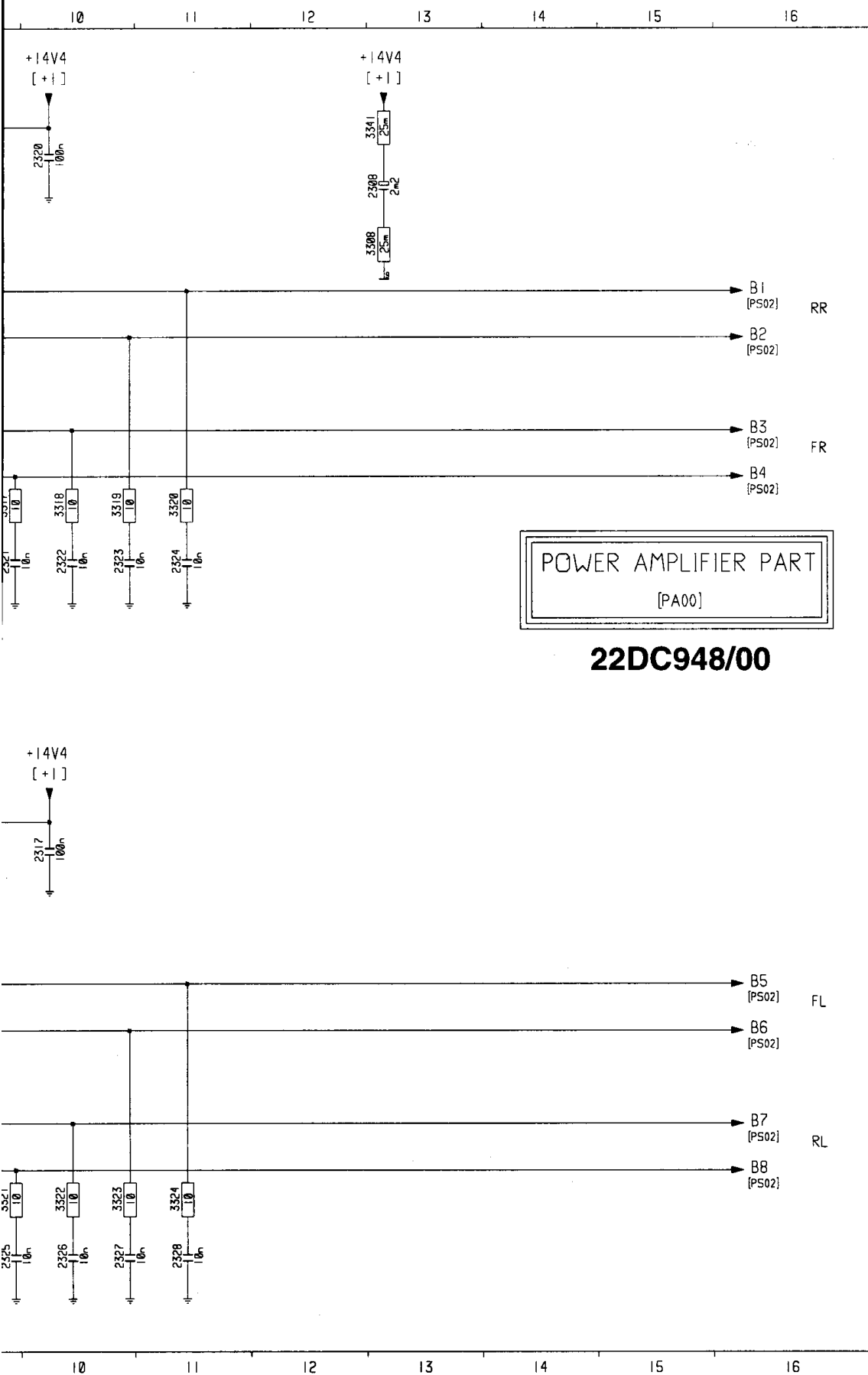

POWER AMPLIFIER PART
[PA00]

22DC948/00

A	2300	K 8
	2301	E 8
	2302	A 4
	2303	H 2
	2304	I 2
	2305	J 2
	2306	J 2
	2308	B13
	2311	J 6
	2313	I 6
B	2314	D 6
	2315	C 6
	2316	E 8
	2317	G10
	2318	K 8
C	2319	G 8
	2320	A10
	2321	E 9
	2322	E10
	2323	E10
D	2324	E11
	2325	K 9
	2326	K10
	2327	K10
	2328	K11
E	2329	G 2
	3300	J 6
	3301	G 2
	3302	F 2
	3304	B 4
	3305	B 2
	3306	A 4
	3307	A 3
	3308	B13
F	3312	I 6
	3313	J 6
	3316	H 6
	3317	D 9
	3318	D10
	3319	D10
G	3320	D11
	3321	J 9
	3322	J10
	3323	J10
	3324	J11
H	3325	D 5
	3326	C 5
	3329	G 3
	3330	A 2
	3341	A13
	3342	B 4
	3343	H 4
I	6300	B 3
	7302	D 8
	7303	J 8
	7304	B 4
	7306	B 2
J		
K		